

**Ashcroft® Switches**

**PIP #: SW-PI-54**

Applicable to:

**SEALED CONDUIT CONNECTION  
XPM VARIATION**

For greater reliability and safety in switch installations, we recommend a Sealed Conduit Connection. This offers several benefits:

- It keeps condensation buildup in conduit runs from entering the switch enclosure, increasing switch life.
- In the unlikely event of a rupture in the pressure sensing diaphragm, any electrical equipment connected through the conduit runs will be protected from the media.
- The potted wires are less likely to be pulled off the micro switch terminals.

A waterproof potting compound is used for environmentally sealing the Nema 4 version (see figure 1 below). The Nema 7 version has a potting dam sandwiched by a thin layer of waterproof potting

compound, and a larger fill of cement sealing compound that makes it suitable for hazardous areas (see figure 2). The material of the adapter is aluminum for B, L, P-Series, and 316 stainless steel for G-Series.

The sealed conduit connection is specified using the XPM variation and is available on single or dual switches. The standard length of the wire leads is 16", however custom lengths can be supplied.

The XPM is available on the B, L, G and P-Series switch lines. When ordered on switches with Nema 4 ratings, the XPM is installed at the factory. UL recommends that the XPM be installed in the field for Nema 7 installations, so the part is shipped as an accessory (in the same box, wrapped separately).

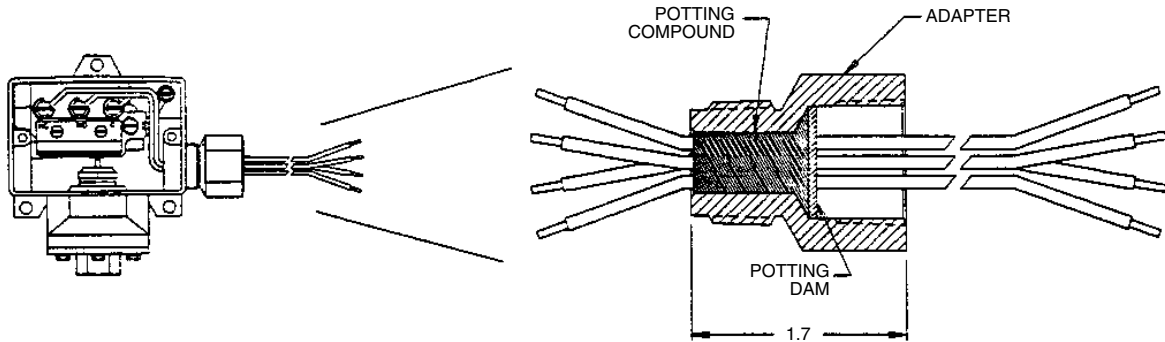

**Figure 1: Example of XPM installation. Detail drawing of Nema 4 Version.**

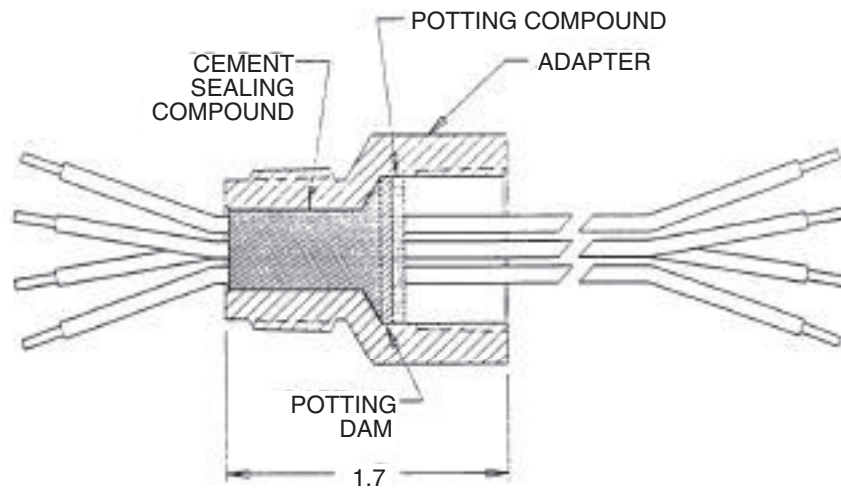

**Figure 2: Nema 7 Version.**

### **HOW TO ORDER**

Typical B-Series Code: **B7 64 B XPM 100 psi**

Typical L, G, P-Series Code: **LPS N4 G V XPM 600 psi**