



Type 80 Wafer and Type 81 Bolt-Thru Isolation Rings

Installation, Maintenance and Safety Instructions

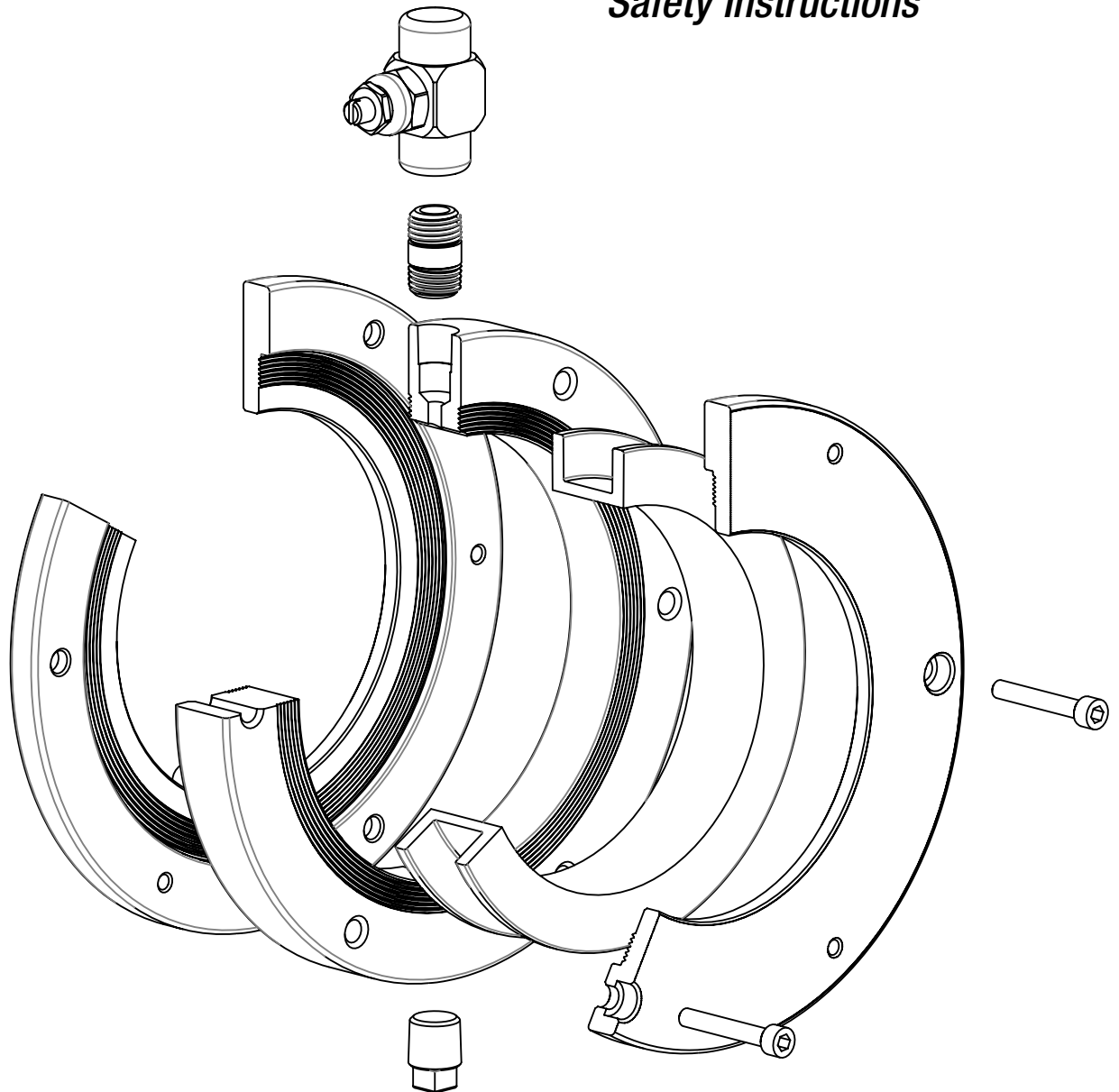

TABLE OF CONTENTS

1. SAFETY INFORMATION
2. OVERVIEW
3. SPECIFICATIONS
4. DIMENSIONAL DRAWINGS
5. PRODUCT INSTALLATION
6. ASSEMBLY REMOVAL
7. PRODUCT MAINTENANCE / IN-SERVICE REPLACEMENT
8. STORAGE

1 - SAFETY INFORMATION

SAFETY INFORMATION

To assure safe operation and maintenance procedures, read and follow these instructions.

⚠ WARNING: Serious injury or equipment damage can result from failure to properly install, maintain or operate these components:

- Follow all instructions in these instructions to avoid exposure to pressurized fluid.
- Use proper tools and safety equipment in installing or maintaining components.
- Assure that process pressures and temperatures are properly monitored and maintained, and that process fluid is appropriate and compatible with system.
- If Safe Quick Release (SQR) option is used with isolation ring, avoid projection hazard by always using two hands to install or remove gauge, and stand clear from the gauge and coupling.

2 - OVERVIEW

OVERVIEW

Isolation rings are designed to protect measuring devices, e.g. pressure gauges, switches, and transducers, from direct contact with the process media. Using a 360-degree flexible liner that eliminates the potential for clogging and/or fouling, while transmitting pressure hydraulically to the instrument. Offered in two styles, Type 80 (Wafer) and Type 81 (Bolt-thru), each is mounted between customer-supplied flanges of process piping; available in nominal pipe sizes from 2" to 20" and 1" to 10", respectively.

3 - PRODUCT SPECIFICATIONS

PRODUCT SPECIFICATIONS

Type/Size:

Type 80 Wafer: 2" to 20"

Type 81 Bolt-Thru: 1" to 10"

Liner Materials: Buna-N, Teflon®, EPDM, Natural Rubber, Viton®

Liner Process Temperature Limits: Buna-N	-30/225°F
Teflon®	-15/350°F
Viton®	-15/350°F
Natural Rubber	-30/225°F
EPDM	-40/300°F

End Plate: 316L SS, Carbon Steel, CPVC

Pressure Class (Type 81 Bolt-Thru only): ANSI/ASME Class 150 / 300 (Type 80 wafer applicable to both 150 and 300 class)

Body: 316L SS, Carbon Steel

Instrument Connection Size: ¼, ½ Female NPT

Fill Fluid: Glycerin, Silicone (10 CST), Silicone (5 CST), Halocarbon.

AVAILABLE PRODUCT OPTIONS

Safe Quick Release Instrument Removal Option: (SQR)

- All Welded Assembly (XDU) – Not available with Safe Quick Release (SQR) and/or Needle Valve
- Retrofit end plates (XIR)
- Wired Stainless Steel Tag (XNH)
- Calibration Chart (XC4) – Measuring instrument attached
Consult factory for additional options

4 - DIMENSION DRAWINGS

DIMENSION DRAWINGS

Type 80 Wafer Isolation Ring

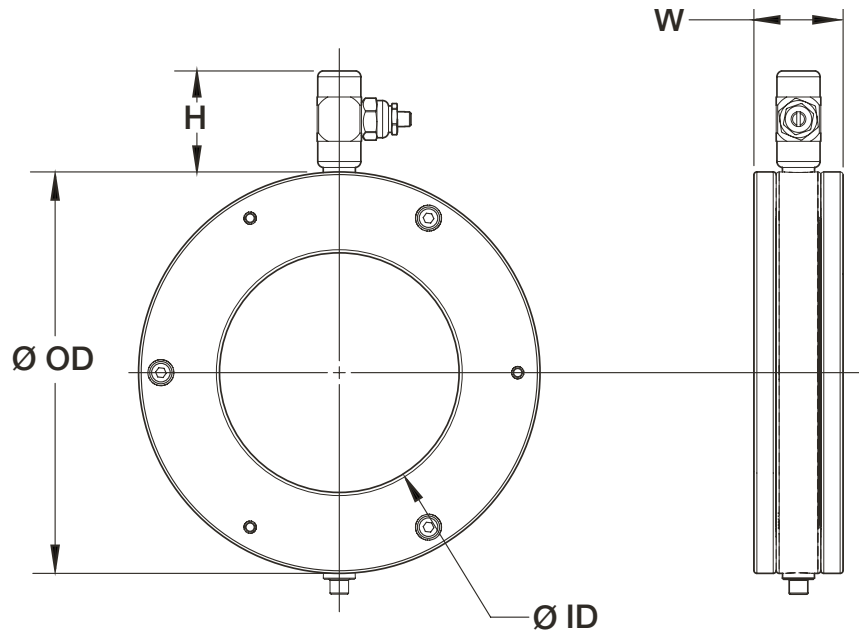

Nominal Pipe Size	Inner Diameter (ID)	Outer Diameter (OD)	Retrofit Width (XIR)	Width (W)	Instrument Removal (H)			Weight Lbs.
					None	Safe Quick Release	Needle Valve	
2"	2.07	4.00	2.13	2.00	1.89	2.04	1.70	4.0
3"	3.07	5.25	2.13	2.00	1.89	2.04	1.70	6.3
4"	4.03	6.75	2.13	1.50	1.89	2.04	1.70	8.0
5"	5.05	7.63	2.25	1.50	1.89	2.04	1.70	
6"	6.07	8.63	2.25	1.50	1.89	2.67	2.32	10.2
8"	7.98	10.88	2.50	1.50	2.39	2.67	2.32	14.9
10"	10.02	13.25	2.75	1.50	2.39	2.67	2.32	21.3
12"	12.00	16.00	3.00	1.75	2.39	2.67	2.32	39.1
14"	13.25	17.63	3.00	1.75	2.89	3.17	2.82	47.8
16"	15.25	20.13	3.00	1.75	2.89	3.17	2.82	61.8
18"	17.25	21.50	3.00	1.75	2.89	3.67	3.32	58.0
20"	19.25	23.75	3.00	1.75	2.89	3.67	3.32	68.6

All dimensions shown in inches.

4 - DIMENSION DRAWINGS

DIMENSION DRAWINGS (cont.)

Type 81 Bolt-Thru Isolation Ring

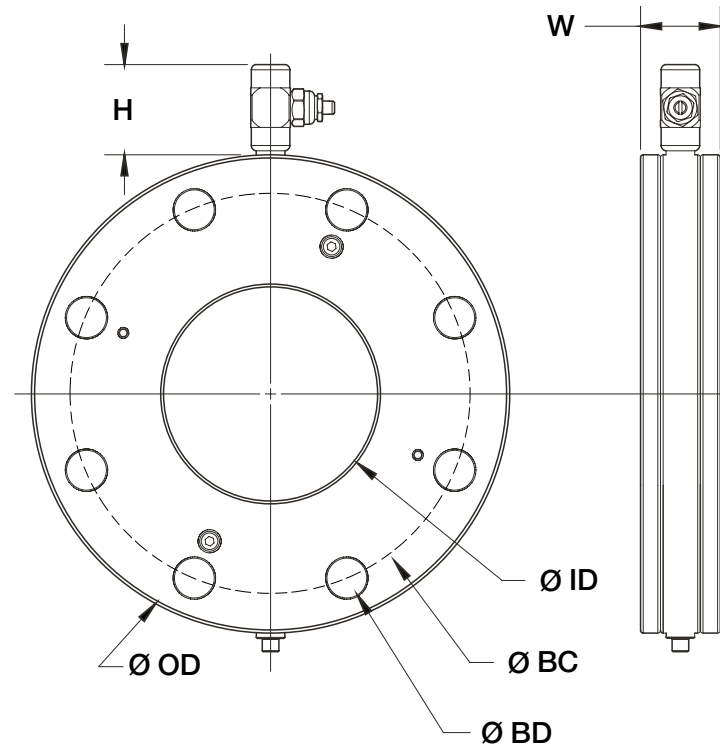

ANSI ASME Class	Nom. Pipe Size	Inner Dia. (ID)	Outer Dia. (OD)	Width (W)	Bolt Circle (BC)	Bolt Dia. (BD)	No. Of Bolt Holes	Instrument Removal (H)			Weight Lbs.
								Direct	Safe Quick Release	Needle Valve	
150	1" SS/CS	1.05	4.25	2.00	3.12	0.625	4	0	2.04	1.70	5.7
	1" CPVC	1.05	4.25	2.25	3.12	0.625	4	0	2.04	1.70	4.0
	1.5" SS/CS	1.61	5.00	2.00	3.88	0.625	4	0	2.04	1.70	7.9
	1.5" CPVC	1.61	5.00	2.25	3.88	0.625	4	0	2.04	1.70	5.6
	2"	2.07	6.00	2.00	4.75	0.75	4	0	2.04	1.70	12.0
	3"	3.07	7.50	2.00	6.00	0.75	4	0	2.04	1.70	18.4
	4"	4.03	9.00	1.50	7.50	0.75	8	0	2.04	1.70	18.6
	5"	5.05	10.00	1.50	8.50	0.88	8	0	2.04	1.70	21.0
	6"	6.07	11.00	1.50	9.50	0.88	8	0	2.04	1.70	23.9
	8"	7.98	13.50	1.50	11.75	0.88	8	0	2.04	1.70	34.5
10"	10.02	16.00	1.50	14.25	1.00	12	0	2.04	1.70	44.5	
300	2"	2.07	6.50	2.00	5.00	0.75	8	0	2.04	1.70	13.8
	3"	3.07	8.25	2.00	6.62	0.88	8	0	2.04	1.70	22.0
	4"	4.03	10.00	1.50	7.88	0.88	8	0	2.04	1.70	24.5
	5"	5.05	11.0	1.50	9.25	0.88	8	0	2.04	1.70	32.0
	6"	6.07	12.50	1.50	10.62	0.88	12	0	2.04	1.70	34.9
	8"	7.98	15.00	1.50	13.00	1.00	12	0	2.04	1.70	47.1
	10"	10.02	17.50	1.50	15.25	1.13	16	0	2.04	1.70	58.8

All dimensions shown in inches.

5 - PRODUCT INSTALLATION

PRODUCT INSTALLATION

MATERIAL COMPATIBILITY: Wetted material selection is critical to the product's life cycle and reliability. In order to ensure proper material selection, elements to consider are:

- Process Fluid
- Process Fluid Concentration (%)
- Process Pressure and Temperature
- Assembly Fill Fluid – check compatibility

Isolation Ring Styles:

Type 80 Wafer:

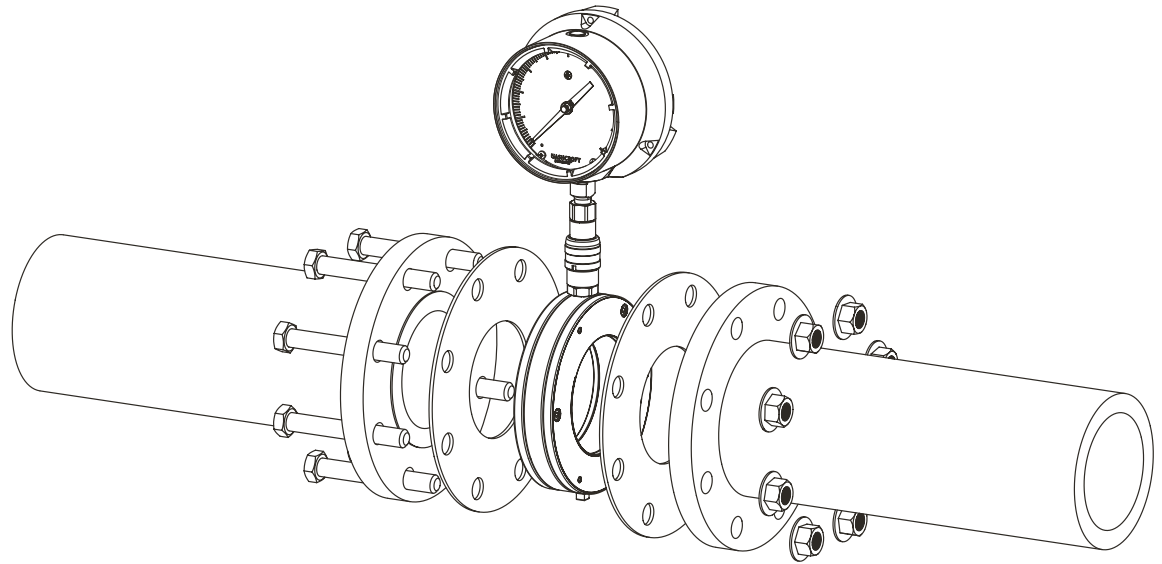

(Exploded View)

Gaskets, nuts, bolts and flanges provided by USER

Type 80 Wafer

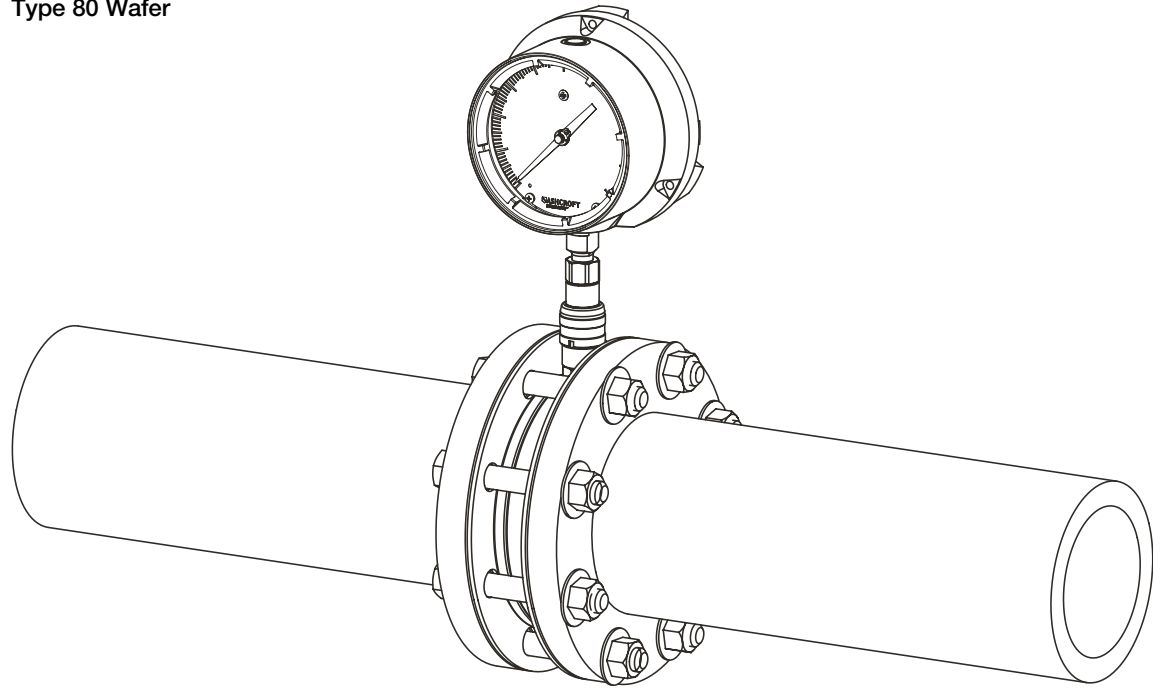

(Installed View)

Type 81 Bolt-Thru

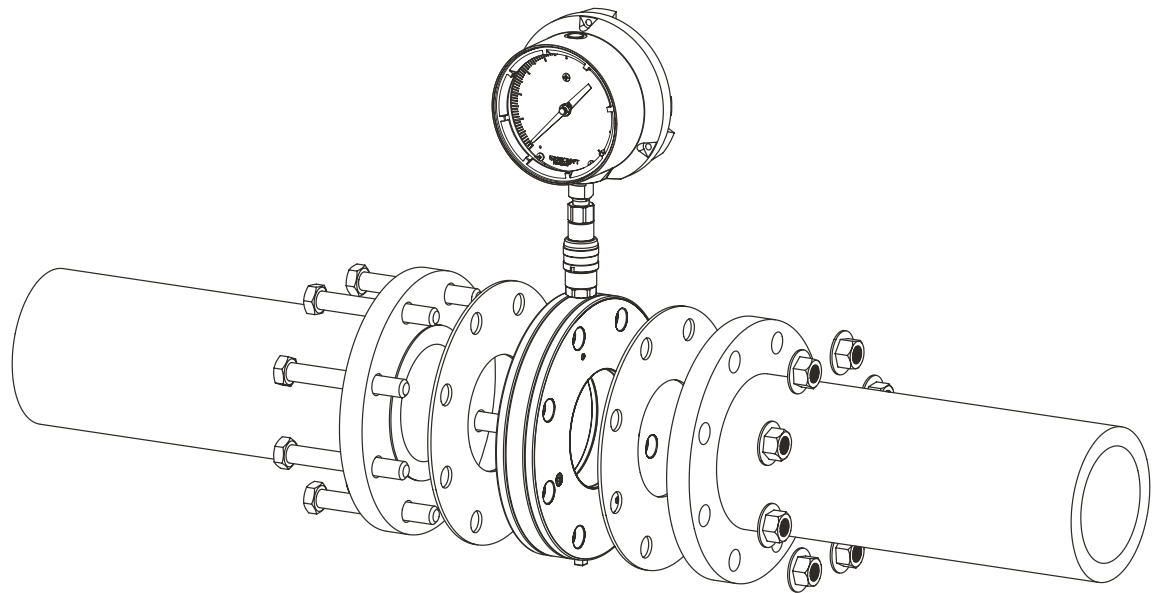

(Exploded View)

Gaskets, nuts, bolts and flanges provided by USER

Type 81 Bolt-Thru

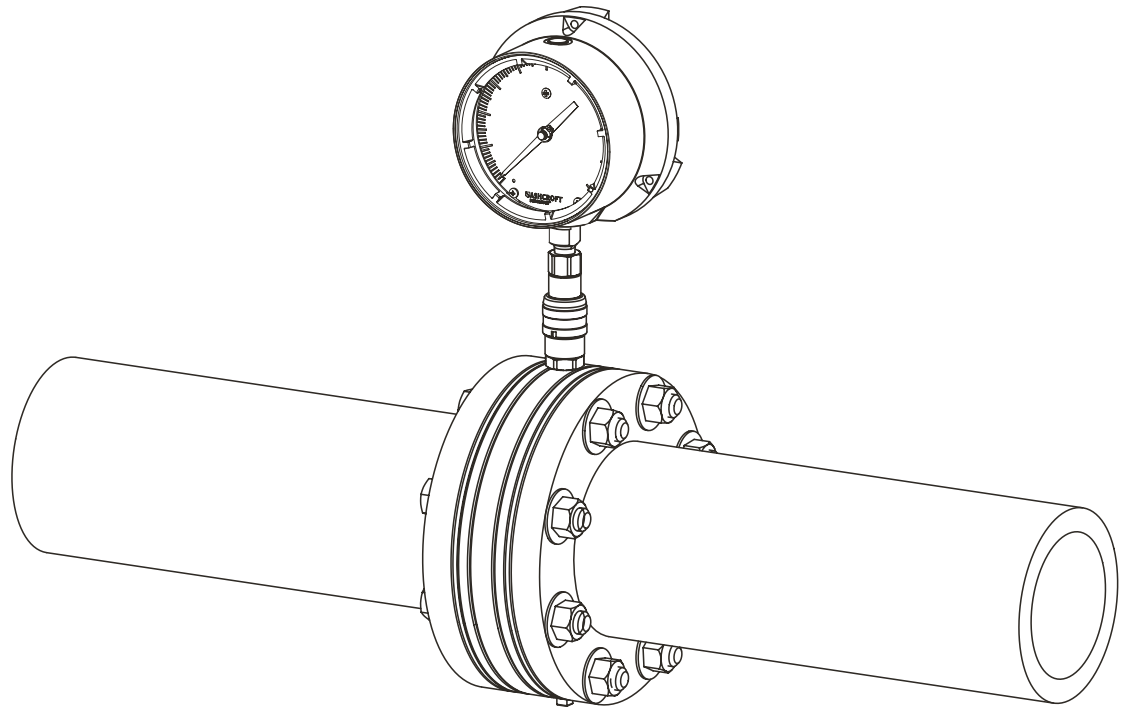

(Installed View)

Prior to installation, please follow the recommended manufacturer procedure:

- A. Confirm process has been shut down with process pressure relieved and piping drained.
- B. Provide pipe flange gasketing, mounting bolts, lockwashers and nuts (not supplied by Ashcroft).

Step 1: Isolation ring and flange gaskets should be centered between process piping flanges.

For Type 80 Wafer: Assembly is installed by placing centering gages (shims) on the two bottom-most flange bolts; these are supplied by Ashcroft with each isolation ring assembly. Refer to the following table for centering gage size based on ANSI/ASME class rating. Note: Centering gauges may be removed afterwards by breaking.

ANSI/ASME CLASS	NPS	CENTERING GAGE SIZE
Class 150	All Sizes	1/8"
Class 300	2"	1/4"
	3"	3/8"
	4"	1/4"
	6"	11/16"
	8"	11/16"
	10"	9/16"
	12"	3/8"
	14"	13/16"
	16"	5/8"
	18"	1-1/16"
20"	1-1/16"	

Step 2: Position Type 80 Wafer isolation ring with centering-gages or Type 81 Bolt-Thru using two bottom-most bolts through unit and process flanges. Take care to ensure that any attached instruments are directed in a vertical (upward) configuration, while measuring devices (e.g. gauge, switch, transducer) are also positioned between the two upper-most flange bolts to prevent obstruction with the process piping.

Step 3: Tighten the piping flange bolts to the locking nuts / washers on the opposite flange. Each should be tightened by cross-bolting with the proper torque based as described in ASME PCC-1 on NPS, ANSI/ASME Class rating, and gasketing used.

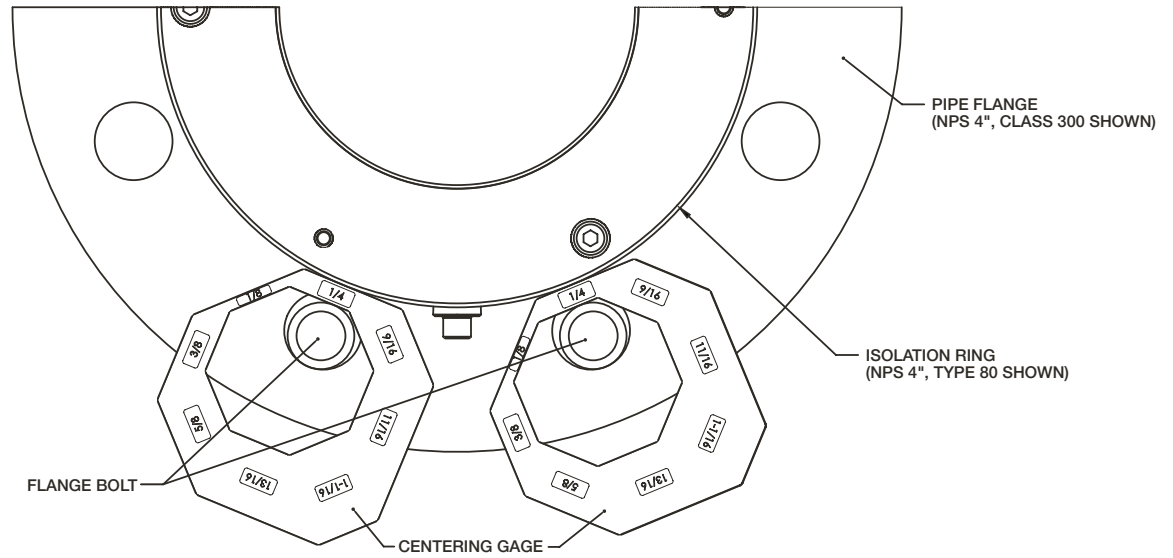

6- ASSEMBLY REMOVAL

ASSEMBLY REMOVAL

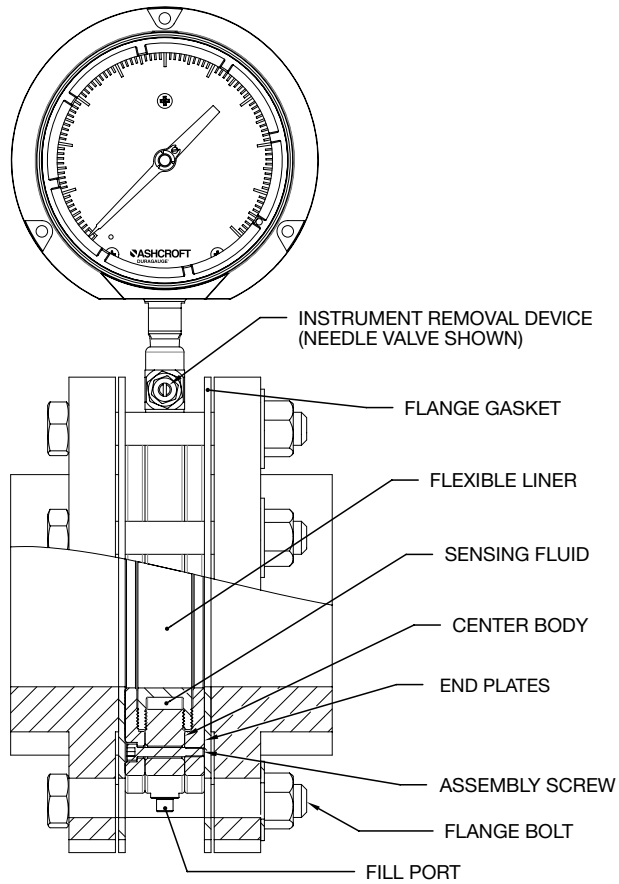

IMPORTANT: In the event the assembly needs to be removed from process, follow the manufacturer's recommended procedure to prevent possible injury and/or damage.

- A. Confirm process has been shut down with process pressure relieved and piping drained, cleaned and dried before installation and/or removal of product assembly.
- B. Ensure the assembly is supported prior to removal of bolts/flanges.

**7 - PRODUCT
MAINTENANCE /
IN-SERVICE
REPLACEMENT**

- C. Loosen flange bolts securing the isolation ring assembly to the process pipe flange.
- D. Upon separation of pipe flanges, remove assembly and flange gaskets from the piping.

In the event only instrument removal is required, use a wrench to unthread the instrument. Use container to catch the fill fluid when draining from the isolation ring.

PRODUCT MAINTENANCE / IN-SERVICE REPLACEMENT

The following provides the user with the necessary instructions to service this product. This will allow the customer to perform routine maintenance that may involve in-service instrument replacement.

IN-SERVICE INSTRUMENT REMOVAL / REPLACEMENT (Dependent upon type of assembly connection listed below)

- 1) **Direct Mount Instrument Removal:** Measuring instrument should never be removed from the isolation ring while in service. For instrument replacement, complete removal of the isolation ring assembly from service is required.
- 2) **Needle Valve Instrument Removal Option:**
 - a) Shut down process and fully vent/relieve pressure to the assembly. While it is possible that pressure may be retained in the process when the instrument is removed, it is imperative that the process pressure **MUST** be at Zero (0 psi) when reinstalling the replacement instrument.
IMPORTANT: Residual pressure may cause potential injury/damage, and replacing an instrument with residual pressure could result in fill fluid imbalance, thereby causing accuracy errors.
 - b) Using a flathead screwdriver, turn the adjustment on the needle valve until fully closed (clockwise).
 - c) Secure the needle valve body using a 3/4" wrench, and remove the attached measuring instrument (e.g. gauge, switch, transducer) with a second wrench applied to the instrument's wrench flats.
 - d) Position and secure the measuring instrument so that the pressure port is facing upwards. Then utilizing an ordinary syringe, fill the internal cavity of the process connection with compatible fill fluid. Place finger on the port and tilt side-to-side to dislodge any trapped air. Continue filling until air bubbles no longer appear. Note: Improper fill can result in accuracy errors or damage to the flexible isolation ring liner. Highly viscous fill fluids may require 10 to 15 minutes until air has been completely dislodged.
 - e) Apply Teflon tape or sealant to instrument fitting while unit is still upside down and place aside while retaining this position.
 - f) Pour fill fluid into instrument until fill fluid is overflowing.
 - g) Using the flathead screwdriver, open the needle valve. Fill needle valve port until fluid is overflowing.
 - h) Once steps e, f and g have been completed, take the filled measuring instrument and quickly "flip" over to install (thread) into the top port of the needle valve. This needs to be performed to lose as little fill fluid as possible.
 - i) Secure both instruments utilizing the two wrenches previously used for disassembly.
- 3) **Safe Quick Release (SQR) Option:** This option provides the end-user with a flexible approach to remove/replace an existing instrument once the isolation ring has been installed. Prior to removal, it will be necessary to obtain a pre-filled instrument to allow continued operation and limit downtime. Record the product model number and pressure at which the instrument has been removed; this is important as it ensures that an exact replacement is "pre-charged" at the factory to retain accuracy. Safe Quick Release (SQR) removal procedure is as follows:
 - a) Ensure process pressure has been relieved to the proper intended removal pressure of the lesser of 300 psi or half-scale of any attached gauge. Recommended removal/replacement of product is 0 psi.
 - b) Twist the instrument so that the coupling sleeve-relief lines up with the sleeve-lock key.
 - c) While holding the instrument securely, pull sleeve downward to disengage coupling.
 - d) Place newly "pre-charged" instrument on the coupling and pressure downward to engage the coupling.

8 - STORAGE

STORAGE

Store in a cool, dry area.

Ashcroft Inc.,
250 East Main Street
Stratford, CT 06614-5145
U.S.A.
Tel: 203-378-8281
Fax: 203-385-0408 (Domestic)
Fax: 203-385-0357 (International)
email: info@ashcroft.com
www.ashcroft.com
80-81_rings_im_RevA_(008-10223) 06-18

Visit our web site www.ashcroft.com