

Installation and Maintenance Instructions for ZT60 High Purity Pressure Transmitter with Display

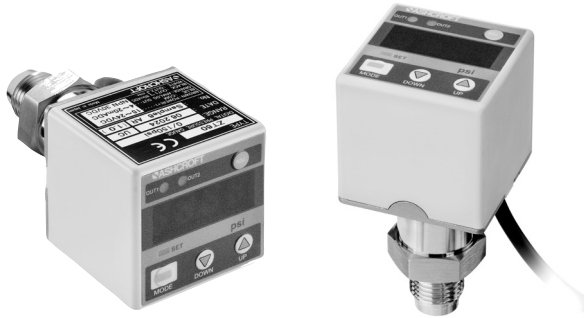

CAUTIONS FOR PROPER AND SAFE OPERATION.

To use this product safely, please read this instruction manual carefully. Incorrect operation may cause malfunction, damage or accident. The cautions and warnings in the document are indicated by the following:

WARNING: Indicates that incorrect use may result in service injury or loss of life.

CAUTION: Indicates that incorrect use may result in service injury or property damage.

WARNING:

1. Do not apply pressure greater than the maximum allowable pressure. This may cause damage or rupture the pressure element, resulting in injury or damage to the surroundings.
2. Do not use this product to measure fluid which causes gas/liquid contact area to corrode. This may cause damage or rupture the pressure element, resulting in injury or damage to the surroundings.
3. Do not apply excessive weight, vibration or shock. This may cause damage or rupture the pressure element, resulting in injury or damage to the surroundings.
4. Use of a non-designated power source may cause fires or electric shocks.
5. Use this device within the operating temperature range. Using the instrument outside of the recommended operating temperature range may cause malfunction or damage and result in injury or damage to the surroundings.
6. Perform wire connection according to the wire connection faceplate or the wire connection instructions within the instruction manual. Incorrect wiring may cause injury or fire.
7. This product is not designed for use in explosion-proof environments. Use explosion-proof product when required or explosive gas exists; this is due to the potential of ignition or explosion.
8. Perform installation according to the instruction manual.

9. Do not alter this product in any manner or form. In addition-
do not disassemble this product. Contact Ashcroft for repairs.
10. Since this product is a precision measuring instrument, it is advised that the product be removed from all sources of noise. Remove noise from the power source by using noise filter, etc.
11. It is recommended to purge this device with inert gas to remove atmospheric particles and foreign materials before installation.

Table of contents:

1. INTRODUCTION	2
2. ATTENTION	2
3. GENERAL DESCRIPTION	2
4. OUTLINE DRAWINGS	3-7
5. PRECAUTIONS FOR USE	
5-1. Transportation precautions	8
5-2. Unpacking precautions	8
5-3. Mounting precautions	8
5-4. Storage precautions	8
6. WIRING DIAGRAMS	9,10
7. MODES AND THEIR FUNCTIONS	11
8. PANEL DISPLAY FUNCTIONS	11
9. PROGRAMMING FOR FUNCTION SETTING MODES	12,13,14
10. COMPARATOR OPERATION	14,15
11. OTHER FUNCTIONS	15,16
12. MAINTENANCE	16
13. WARRANTY	16

Installation and Maintenance Instructions for ZT60 High Purity Pressure Transmitter with Display



1. INTRODUCTION

Please double-check the specifications for the model that you have received.

If specifications such as the pressure range, power source, or output are incorrect, accidents can occur. Please be sure to use a model that is appropriate for your specifications, in a location which is appropriate for your usage environment, and which has been correctly wired and installed.

2. ATTENTION

Ashcroft shall have no liability for failure, product issue, or physical injury resulting from the following:

- Modification and repair performed by any non-Ashcroft personnel.
- Product issue caused by product of another company
- Misuse of product instructions, instrument operation and/or not observing conditions/methods stipulated within the instruction manual.
- Natural disasters, such as fire, seismic activity, water/flood damage, lightning, etc.

3. GENERAL DESCRIPTION

This high purity pressure transmitter with display has been developed for the semiconductor industry. It incorporates a digital display which features the ability to program functions such as scaling, loop check, comparator output and several other functions suitable for use with semiconductor processes and high purity gases.

4. OUTLINE DRAWINGS & DIMENSIONS

(See the following pages 3 -7)

**ZT60
Key Pad**



**ZT60
Specification Label**

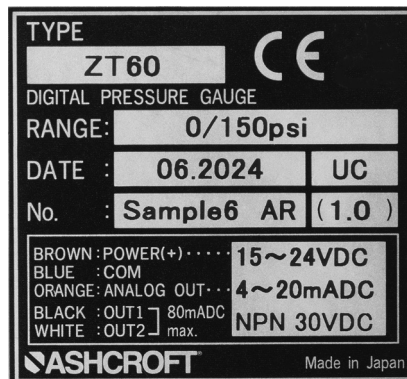

Installation and Maintenance Instructions for ZT60 High Purity Pressure Transmitter with Display



Dimensions are in inches [mm] for UC/BA/EP/GP Grade

Horizontal Mounting - Type T - Male Integrated

UC/BA Grade

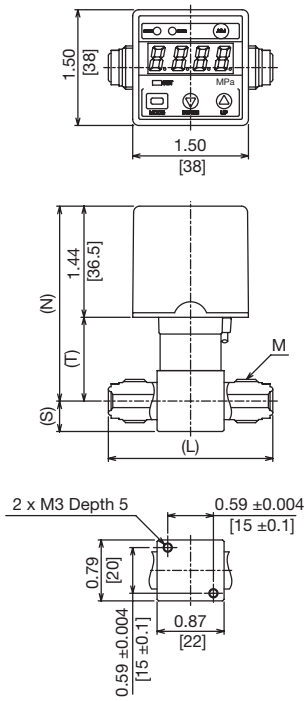

Compatible with 1/4 VCR®

EP/GP Grade

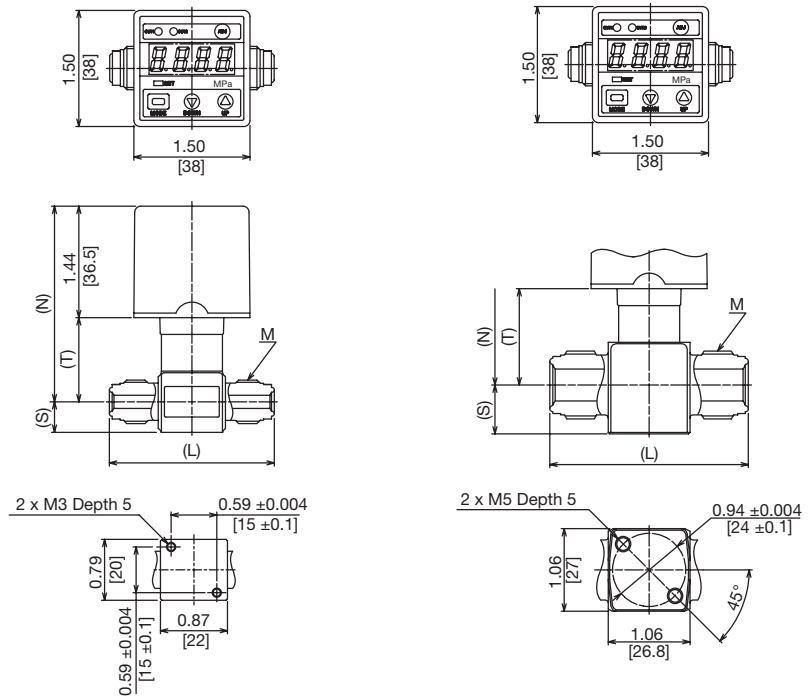

Compatible with 1/2 (3/8) VCR®

Grade	Connection	Piping Dia.	Screw Size M	Dimensions				Model Number
				N	T	S	L	
UC	Compatible with VCR® Male Intergrated	1/4	9/16-18UNF	2.52 [64]	1.08 [27.5]	0.39 [10]	2.13 [54]	ZT60-136

Grade	Connection	Piping Dia.	Screw Size M	Dimensions				Model Number
				N	T	S	L	
BA	Compatible with VCR® Male Intergrated	1/4	9/16-18UNF	2.52 [64]	1.08 [27.5]	0.39 [10]	2.13 [54]	ZT60-13N

Grade	Connection	Piping Dia.	Screw Size M	Dimensions				Model Number
				N	T	S	L	
EP	Compatible with VCR® Male Intergrated	1/4	9/16-18UNF	2.52 [64]	1.08 [27.5]	0.39 [10]	2.13 [54]	ZT60-13E
		1/2 (3/8)	7/8-14	2.68 [68]	1.24 [31.5]	0.63 [16]	2.56 [65]	ZT60-14E

Grade	Connection	Piping Dia.	Screw Size M	Dimensions				Model Number
				N	T	S	L	
GP	Compatible with VCR® Male Intergrated	1/4	9/16-18UNF	2.52 [64]	1.08 [27.5]	0.39 [10]	2.13 [54]	ZT60-13G

Installation and Maintenance Instructions for ZT60 High Purity Pressure Transmitter with Display



Dimensions are in inches [mm] for UC/BA Grade

Horizontal Mounting - Type T - Male Nut / Female Nut

UC Grade

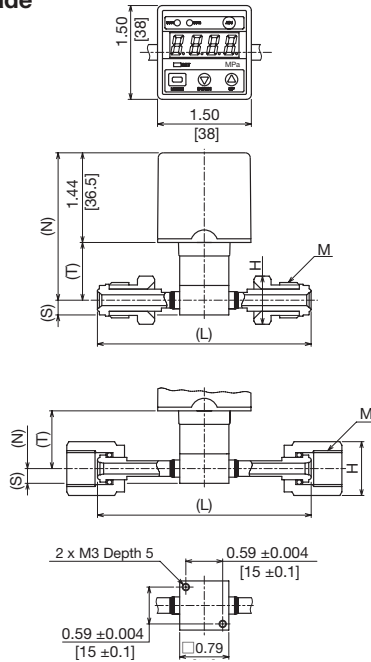

BA Grade

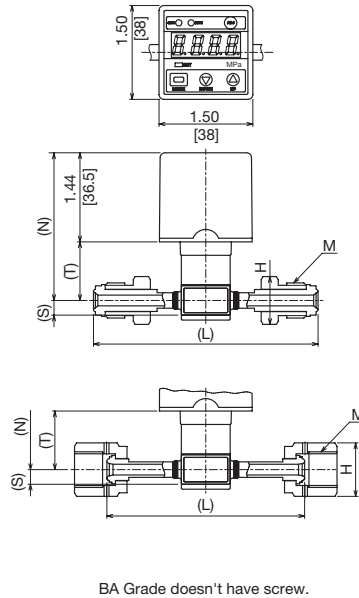

Grade	Connection	Piping Dia.	Screw Size M	Dimensions					Model Number
				N	T	S	H	L	
UC	VCR® Male Nut	¼	9/16-18UNF	2.36 [60]	0.93 [23.5]	0.24 [6]	0.63 x 0.73 [16 x 18.5] Hex	3.39 [86]	ZT60-1J6
		¾	7/8-14UNF	2.58 [65.5]	1.14 [29]	0.28 [7]	0.94 x 1.09 [24 x 27.7] Hex	3.56 [90.5]	ZT60-1K6
	VCR® Female Nut (Bearings are not included)	¼	9/16-18UNF	2.36 [60]	0.93 [23.5]	0.24 [6]	0.75 x 0.86 [19 x 21.9] Hex	3.18 [80.8]	ZT60-1L6
		¾	7/8-14UNF	2.58 [65.5]	1.14 [29]	0.28 [7]	1.06 x 1.23 [27 x 31.2] Hex	3.22 [81.8]	ZT60-1M6
	UJR Male Nut	¼	9/16-18UNF	2.36 [60]	0.93 [23.5]	0.24 [6]	0.67 x 0.77 [17 x 19.6] Hex	3.43 [87]	ZT60-1N6
		¾	7/8-14UNF	2.58 [65.5]	1.14 [29]	0.28 [7]	0.91 x 1.05 [23 x 26.6] Hex	3.94 [100]	ZT60-1P6
	UJR Female Nut (With pure ring)	¼	9/16-18UNF	2.36 [60]	0.93 [23.5]	0.24 [6]	0.75 x 0.86 [19 x 21.9] Hex	3.43 [87]	ZT60-1Q6
		¾	7/8-14UNF	2.58 [65.5]	1.14 [29]	0.28 [7]	1.02 x 1.18 [26 x 30] Hex	3.94 [100]	ZT60-1R6
	CVC Male Nut	¼	9/16-18UNF	2.36 [60]	0.93 [23.5]	0.24 [6]	0.62 x 0.72 [15.8 x 18.2] Hex	3.39 [86]	ZT60-1W6
		¾	7/8-14UNF	2.58 [65.5]	1.14 [29]	0.28 [7]	0.94 x 1.08 [23.8 x 27.5] Hex	3.57 [90.6]	ZT60-1X6
	CVC Female Nut (Bearings are not included)	¼	9/16-18UNF	2.36 [60]	0.93 [23.5]	0.24 [6]	0.75 x 0.86 [19 x 21.9] Hex	3.18 [80.8]	ZT60-1Y6
		¾	7/8-14UNF	2.58 [65.5]	1.14 [29]	0.28 [7]	1.06 x 1.23 [27 x 31.2] Hex	3.23 [82]	ZT60-1Z6

Grade	Connection	Piping Dia.	Screw Size M	Dimensions					Model Number
				N	T	S	H	L	
BA	VCR® Male Nut	¼	9/16-18UNF	2.38 [60.5]	0.94 [24]	0.24 [6]	0.63 x 0.73 [16 x 18.5] Hex	3.39 [86]	ZT60-1JN
	VCR® Female Nut (Bearings are not included)						0.75 x 0.86 [19 x 21.9] Hex	3.18 [80.8]	ZT60-1LN
	UJR Male Nut						0.67 x 0.77 [17 x 19.6] Hex	3.62 [92]	ZT60-1NN
	UJR Female Nut (Without pure ring)						0.75 x 0.86 [19 x 21.9] Hex	3.19 [81]	ZT60-1QN
	CVC Male Nut						0.62 x 0.72 [15.8 x 18.2] Hex	3.39 [86]	ZT60-1WN
	CVC Female Nut (Bearings are not included)						0.75 x 0.86 [19 x 21.9] Hex	3.18 [80.8]	ZT60-1YN

Installation and Maintenance Instructions for ZT60 High Purity Pressure Transmitter with Display



Dimensions are in inches [mm] for EP/GP Grade

Horizontal Mounting - Type T - Male Nut / Female Nut

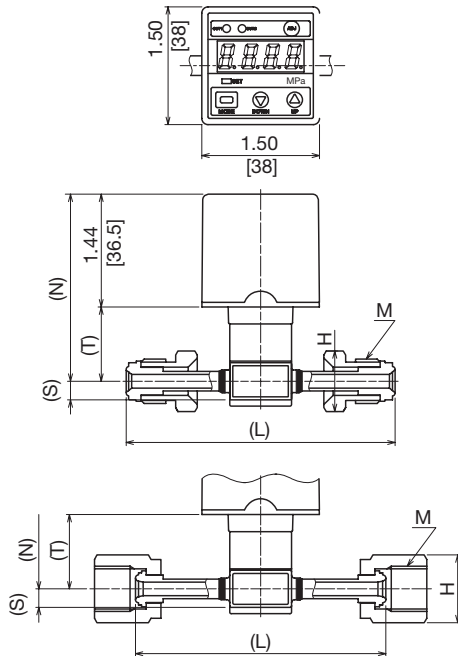

* There is no M3 screw on the piping diameter 1/4.

1/4UJR

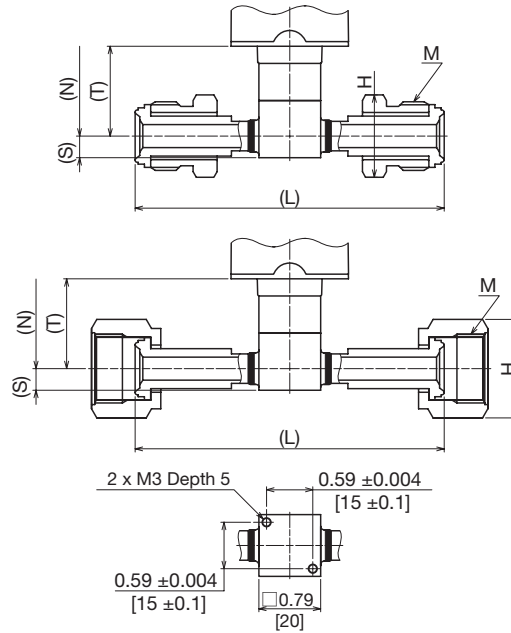

3/8UJR

Grade	Connection	Piping Dia.	Screw Size M	Dimensions					Model Number
				N	T	S	H	L	
EP	UJR Male Nut	1/4	9/16-18UNF	2.38 [60.5]	0.94 [24]	0.24 [6]	0.67 x 0.77 [17 x 19.6] Hex	3.43 [87]	ZT60-1NE
		3/8	7/8-14UNF	2.58 [65.5]	1.14 [29]	0.28 [7]	0.91 x 1.05 [23 x 26.6] Hex	3.94 [100]	ZT60-1PE
	UJR Female Nut (Without pure ring)	1/4	9/16-18UNF	2.38 [60.5]	0.94 [24]	0.24 [6]	0.75 x 0.86 [19 x 21.9] Hex	3.19 [81]	ZT60-1QE
		3/8	7/8-14UNF	2.58 [65.5]	1.14 [29]	0.28 [7]	1.02 x 1.18 [26 x 30] Hex	3.94 [100]	ZT60-1RE
GP	UJR Male Nut	1/4	9/16-18UNF	2.38 [60.5]	0.94 [24]	0.24 [6]	0.67 x 0.77 [17 x 19.6] Hex	3.43 [87]	ZT60-1NG
							0.75 x 0.86 [19 x 21.9] Hex	3.19 [81]	ZT60-1QG

Installation and Maintenance Instructions for ZT60 High Purity Pressure Transmitter with Display



Dimensions are in inches [mm] for UC/BA/EP/GP Grade

Horizontal Mounting - Type S - Male Integrated

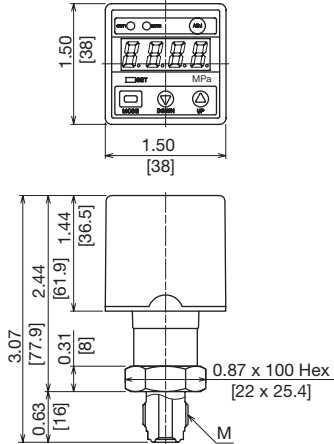

Compatible with 1/4 VCR

Horizontal Mounting - Type S - Male Nut / Female Nut

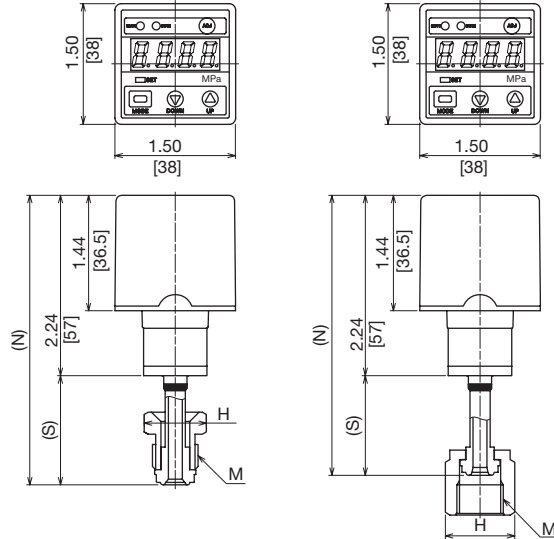

Grade	Connection	Piping Dia.	Screw Size M	Model Number
UC	Compatible with VCR® Male Integrated	1/4	9/16-18UNF	ZT60-236

Grade	Connection	Piping Dia.	Screw Size M	Dimensions			Model Number
				N	S	H	
UC	VCR® Male Nut	1/4	9/16-18UNF	3.58 [91]	1.39 [34]	0.63 x 0.73 [16 x 18.5] Hex	ZT60-2J6
	VCR® Female Nut (Bearings are not included)			3.48 [88.4]	1.24 [31.4]	0.75 x 0.86 [19 x 21.9] Hex	ZT60-2L6
	UJR Male Nut			3.70 [94]	1.46 [37]	0.67 x 0.77 [17 x 19.6] Hex	ZT60-2N6
	UJR Female Nut (With pure ring)			3.60 [91.5]	1.41 [34.5]	0.75 x 0.86 [19 x 21.9] Hex	ZT60-2Q6
	CVC Male Nut			3.66 [93]	1.42 [36]	0.62 x 0.72 [15.8 x 18.2] Hex	ZT60-2W6
	CVC Female Nut (Bearings are not included)			3.48 [88.4]	1.24 [31.4]	0.75 x 0.86 [19 x 21.9] Hex	ZT60-2Y6

Grade	Connection	Piping Dia.	Screw Size M	Model Number
BA	Compatible with VCR® Male Integrated	1/4	9/16-18UNF	ZT60-23N

Grade	Connection	Piping Dia.	Screw Size M	Dimensions			Model Number
				N	S	H	
BA	VCR® Male Nut	1/4	9/16-18UNF	3.58 [91]	1.39 [34]	0.63 x 0.73 [16 x 18.5] Hex	ZT60-2JN
	VCR® Female Nut (Bearings are not included)			3.10 [78.8]	0.86 [21.8]	0.75 x 0.86 [19 x 21.9] Hex	ZT60-2LN
	UJR Male Nut			3.70 [94]	1.46 [37]	0.67 x 0.77 [17 x 19.6] Hex	ZT60-2NN
	UJR Female Nut (Without pure ring)			3.10 [78.7]	0.85 [21.7]	0.75 x 0.86 [19 x 21.9] Hex	ZT60-2QN
	CVC Male Nut			3.66 [93]	1.42 [36]	0.62 x 0.72 [15.8 x 18.2] Hex	ZT60-2WN
	CVC Female Nut (Bearings are not included)			3.48 [88.4]	1.24 [31.4]	0.75 x 0.86 [19 x 21.9] Hex	ZT60-2YN

Grade	Connection	Piping Dia.	Screw Size M	Model Number
EP	Compatible with VCR® Male Integrated	1/4	9/16-18UNF	ZT60-23E

Grade	Connection	Piping Dia.	Screw Size M	Dimensions			Model Number
				N	S	H	
EP	UJR Male Nut	1/4	9/16-18UNF	3.60 [91.5]	1.41 [34.5]	0.67 x 0.77 [17 x 19.6] Hex	ZT60-2NE
	UJR Female Nut (Without pure ring)			3.48 [88.5]	1.24 [31.5]	0.75 x 0.86 [19 x 21.9] Hex	ZT60-2QE

Grade	Connection	Piping Dia.	Screw Size M	Model Number
GP	Compatible with VCR® Male Integrated	1/4	9/16-18UNF	ZT60-23G

Grade	Connection	Piping Dia.	Screw Size M	Dimensions			Model Number
				N	S	H	
GP	UJR Male Nut	1/4	9/16-18UNF	3.60 [91.5]	1.41 [34.5]	0.67 x 0.77 [17 x 19.6] Hex	ZT60-2NG
	UJR Female Nut (Without pure ring)			3.48 [88.5]	1.24 [31.5]	0.75 x 0.86 [19 x 21.9] Hex	ZT60-2QG

Installation and Maintenance Instructions for ZT60 High Purity Pressure Transmitter with Display



Dimensions are in inches [mm] for UC/BA/EP/GP Grade

Vertical Mounting - Type S - Male Integrated

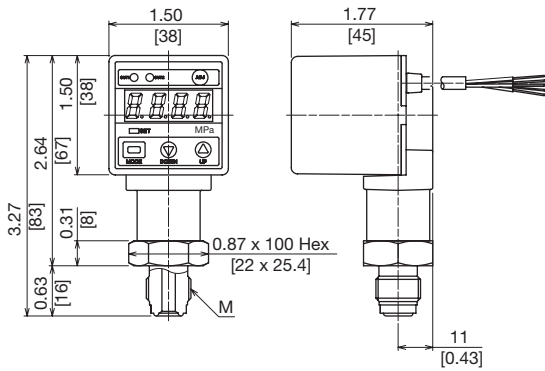

Compatible with 1/4 VCR

Vertical Mounting - Type S - Male Nut / Female Nut

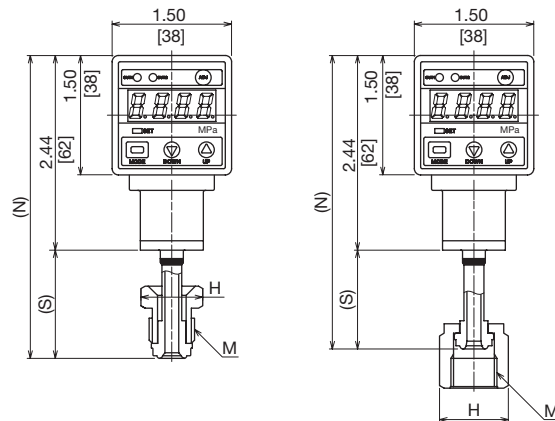

Grade	Connection	Piping Dia.	Screw Size M	Model Number
UC	Compatible with VCR® Male Integrated	1/4	9/16-18UNF	ZT60-A36

Grade	Connection	Piping Dia.	Screw Size M	Dimensions			Model Number
				N	S	H	
UC	VCR® Male Nut	1/4	9/16-18UNF	3.78 [96]	1.39 [34]	0.63 x 0.73 [16 x 18.5] Hex	ZT60-AJ6
	VCR® Female Nut (Bearings are not included)			3.68 [93.4]	1.24 [31.4]	0.75 x 0.86 [19 x 21.9] Hex	ZT60-AL6
	UJR Male Nut			3.90 [99]	1.46 [37]	0.67 x 0.77 [17 x 19.6] Hex	ZT60-AN6
	UJR Female Nut (With pure ring)			3.80 [96.5]	1.41 [34.5]	0.75 x 0.86 [19 x 21.9] Hex	ZT60-AQ6
	CVC Male Nut			3.86 [98]	1.42 [36]	0.62 x 0.72 [15.8 x 18.2] Hex	ZT60-AW6
	CVC Female Nut (Bearings are not included)			3.68 [93.4]	1.24 [31.4]	0.75 x 0.86 [19 x 21.9] Hex	ZT60-AY6

Grade	Connection	Piping Dia.	Screw Size M	Model Number
BA	Compatible with VCR® Male Integrated	1/4	9/16-18UNF	ZT60-A3N

Grade	Connection	Piping Dia.	Screw Size M	Dimensions			Model Number
				N	S	H	
BA	VCR® Male Nut	1/4	9/16-18UNF	3.78 [96]	1.39 [34]	0.63 x 0.73 [16 x 18.5] Hex	ZT60-AJN
	VCR® Female Nut (Bearings are not included)			3.30 [83.8]	0.86 [21.8]	0.75 x 0.86 [19 x 21.9] Hex	ZT60-ALN
	UJR Male Nut			3.90 [99]	1.46 [37]	0.67 x 0.77 [17 x 19.6] Hex	ZT60-ANN
	UJR Female Nut (Without pure ring)			3.30 [83.7]	0.85 [21.7]	0.75 x 0.86 [19 x 21.9] Hex	ZT60-AQN
	CVC Male Nut			3.86 [98]	1.42 [36]	0.62 x 0.72 [15.8 x 18.2] Hex	ZT60-AWN
	CVC Female Nut (Bearings are not included)			3.68 [93.4]	1.24 [31.4]	0.75 x 0.86 [19 x 21.9] Hex	ZT60-AYN

Grade	Connection	Piping Dia.	Screw Size M	Model Number
EP	Compatible with VCR® Male Integrated	1/4	9/16-18UNF	ZT60-A3E

Grade	Connection	Piping Dia.	Screw Size M	Dimensions			Model Number
				N	S	H	
EP	UJR Male Nut	1/4	9/16-18UNF	3.80 [96.5]	1.41 [34.5]	0.67 x 0.77 [17 x 19.6] Hex	ZT60-ANE
	UJR Female Nut (Without pure ring)			3.68 [93.5]	1.24 [31.5]	0.75 x 0.86 [19 x 21.9] Hex	ZT60-AQE

Grade	Connection	Piping Dia.	Screw Size M	Model Number
GP	Compatible with VCR® Male Integrated	1/4	9/16-18UNF	ZT60-A3G

Grade	Connection	Piping Dia.	Screw Size M	Dimensions			Model Number
				N	S	H	
GP	UJR Male Nut	1/4	9/16-18UNF	3.80 [96.5]	1.41 [34.5]	0.67 x 0.77 [17 x 19.6] Hex	ZT60-ANG
	UJR Female Nut (Without pure ring)			3.68 [93.5]	1.24 [31.5]	0.75 x 0.86 [19 x 21.9] Hex	ZT60-AQG

5. PRECAUTIONS FOR USE

5.1 Transportation Precautions

 **CAUTION:** This is a precision measuring instrument. Do not drop or impact when transporting as shock may cause damage and render the instrument inoperable.

5.2 Unpacking Precautions

- Check packaging appearance prior to unpacking.
- Carefully handle and do not drop unit carton.
-  **CAUTION:** • Open instrument's sealed bag in a clean environment. Do not expose the wetted parts of the pressure transmitter to moisture, dust etc.
- Upon unpacking, inspect unit to verify that the model type and physical appearance are correct and free from damage.
- Contact distributor or Ashcroft if any abnormality has been identified with the product.

5.3 Installation Precautions

(1) The ZT60 high purity pressure transmitter with display is designed for installation using UJR, VCR and CVC fittings. Please make sure the proper gaskets are used for installation. Also make sure to use hexagonal flats to tighten all fittings. Do not apply force to the unit enclosure when attached to the pressure line.

For longer-term operation, select a location that is not exposed to direct sunlight, condensation, dust, oil or water. In addition, please pay particular attention to the following during installation.

- Do not drop or impact unit as shock may render unit inoperable.
- Do not install product in an environment exposed to vibration, impact, direct sunlight or dust.
- Use product in ambient temperatures between 14 to 122 °F (-10 to 50 °C)
- Allow for space around the instrument for maintenance and adjustment.
- Do not touch or breathe on the gas contact parts, while taking care not to damage the Indicates that incorrect use may result in service injury or loss of life.seat surface.

 **CAUTION:** • Do not apply excessive force to the enclosure during installation.

 **WARNING:** • Prior to installation, verify that the rating of the power source complies with listed power requirements.

- Do not apply excessive force or excessive bending to the cable once the connector is attached to the product and the mating connector.
- Do not conduct snoop test on this pressure transmitter as it may deteriorate the insulation resistance.
- Prior to commencing operation, it is recommended to purge the unit with sufficient inert gas. This will remove any atmospheric component, particles, and/or foreign matter within the pipe

5.4 Storage Precautions

- To avoid failure or damage, do not store product under the following conditions:
- Do not expose to water
- Susceptible to adverse effects due to air pressure, temperature, humidity, ventilation, sunlight, particles, salt or sulfur in the air

-  **CAUTION:**
- Do not expose to inclination, vibration or shock (including during transportation)
 - Do not expose to chemicals (chemicals' storage area) or gas
 - Do not expose to direct sunlight or high temperature
 - Deformation and discoloration of resin parts may occur when product is stored in a sealed bag under high temperature and high humidity environments.

6. WIRING DIAGRAMS

Electric Connection

Colored cables are used as described below. Confirm the connection before power is on. Warm up the unit and allow it to stabilize for about five minutes after power up before adjusting the zero point and starting measurements.

Wiring for Analog Outputs

- Brown - Power source (+)
- Blue - Common for power source (-) and analog output (-)
- Black - Open collector output 1
- White - Open collector output 2
- Orange - Analog output (+)

Internal Type

Output Type: The comparator output comprises open collector output. The analog output comprises 4 to 20 mA current output or any of the voltage outputs.

“Open collector” means that the collector of an output transistor is open for the user to use for any desired user defined application. Accordingly, the user is free to use the open collector output in any way.

The output transistor is rated for 30 Vdc, 80 mA.

Be sure not to exceed this rating.

6.1. Wiring for open NPN Collector a. with relay

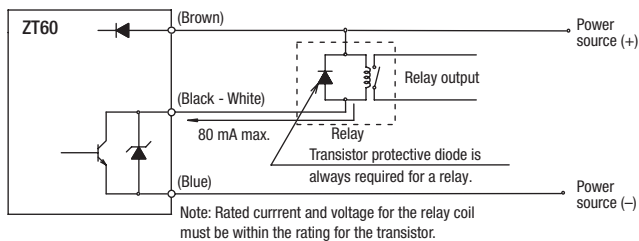

b. with photocoupler

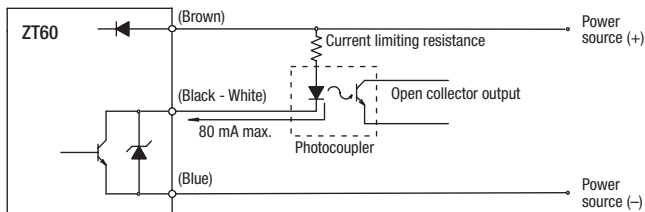

c. Voltage Output

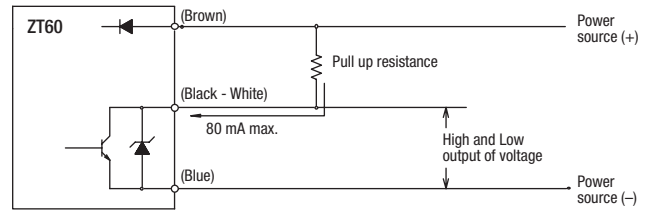

6.2. Wiring for open PNP Collector a. with relay

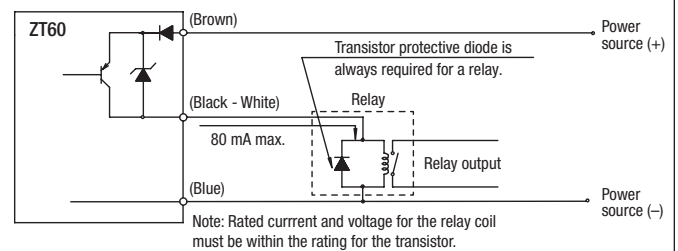

b. with photocoupler

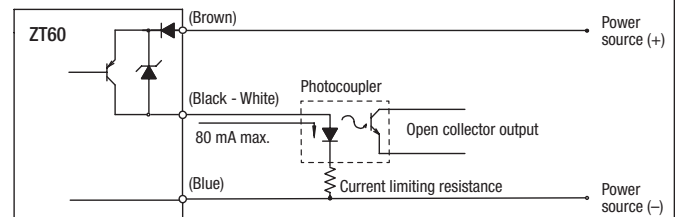

c. Voltage Output

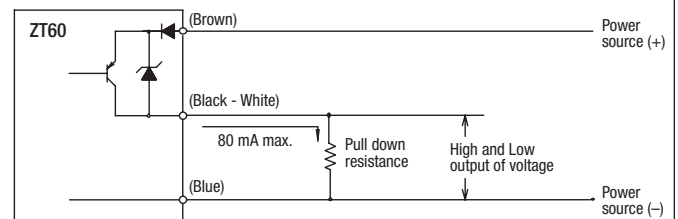

WIRING DIAGRAMS (continued)

**6.3. Wiring for Analog Outputs
a. 4-20 mA output**

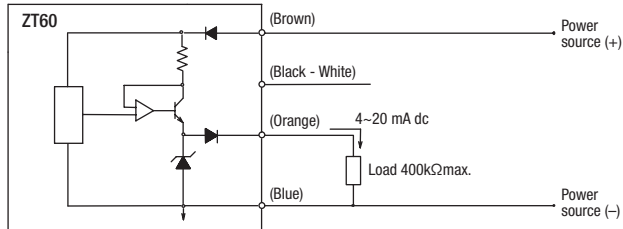

b. Voltage Output: 1-5 Vdc

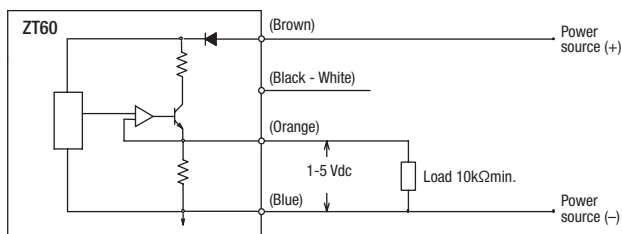

Noise Precautions

Power Lines

Noise on the power lines can cause fluctuating pressure indication and incorrect operation. Check the cable routing for the DC power lines and use a power source of a high noise removal rate.

Output Lines

The internal circuit of the open collector output is connected to that of the output line. Take a special care when routing the wires and make the wires as short as possible.

Induced Noise

The unit may operate erroneously when subjected to external induction. Keep off a noise source, change the direction, or provide a magnetic or static shield, etc.

7. MODES AND THEIR FUNCTIONS

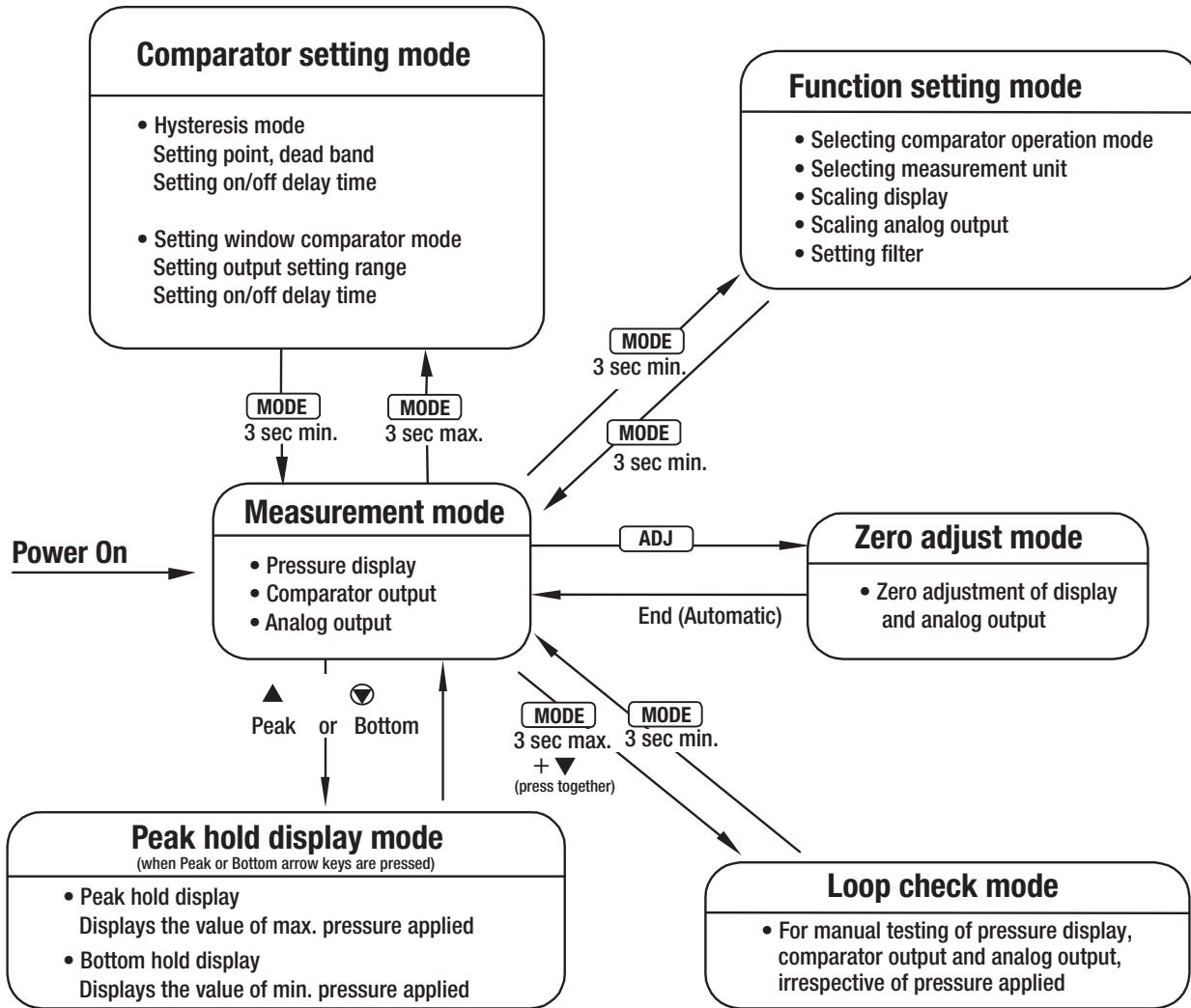

8. PANEL DISPLAY FUNCTIONS

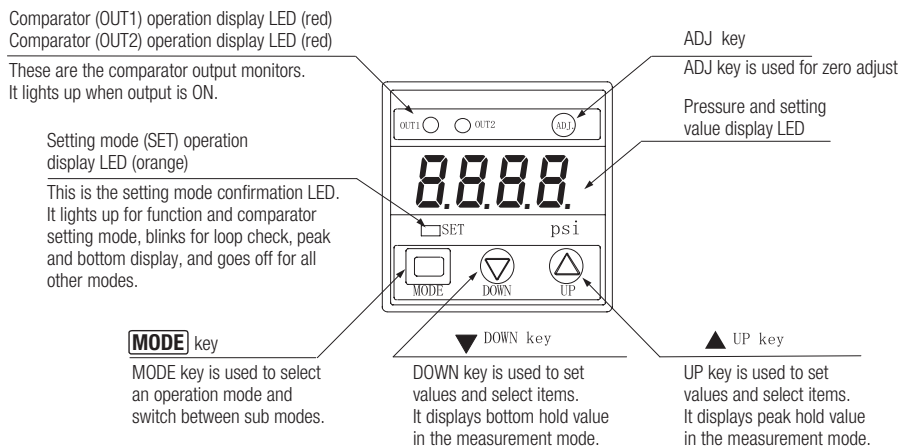

9. PROGRAMMING FOR FUNCTION SETTING MODES

9.1. Programming Procedure

The programming mode is activated by pressing the Mode Key for more than 3 seconds. The Set LED will light up to let you know that you are in the programming mode.

The programming mode can be used to set the comparator output, unit of measure, filtering (response time) and scaling of the analog output.

9.2 Basic Programming Map for Function Setting Modes

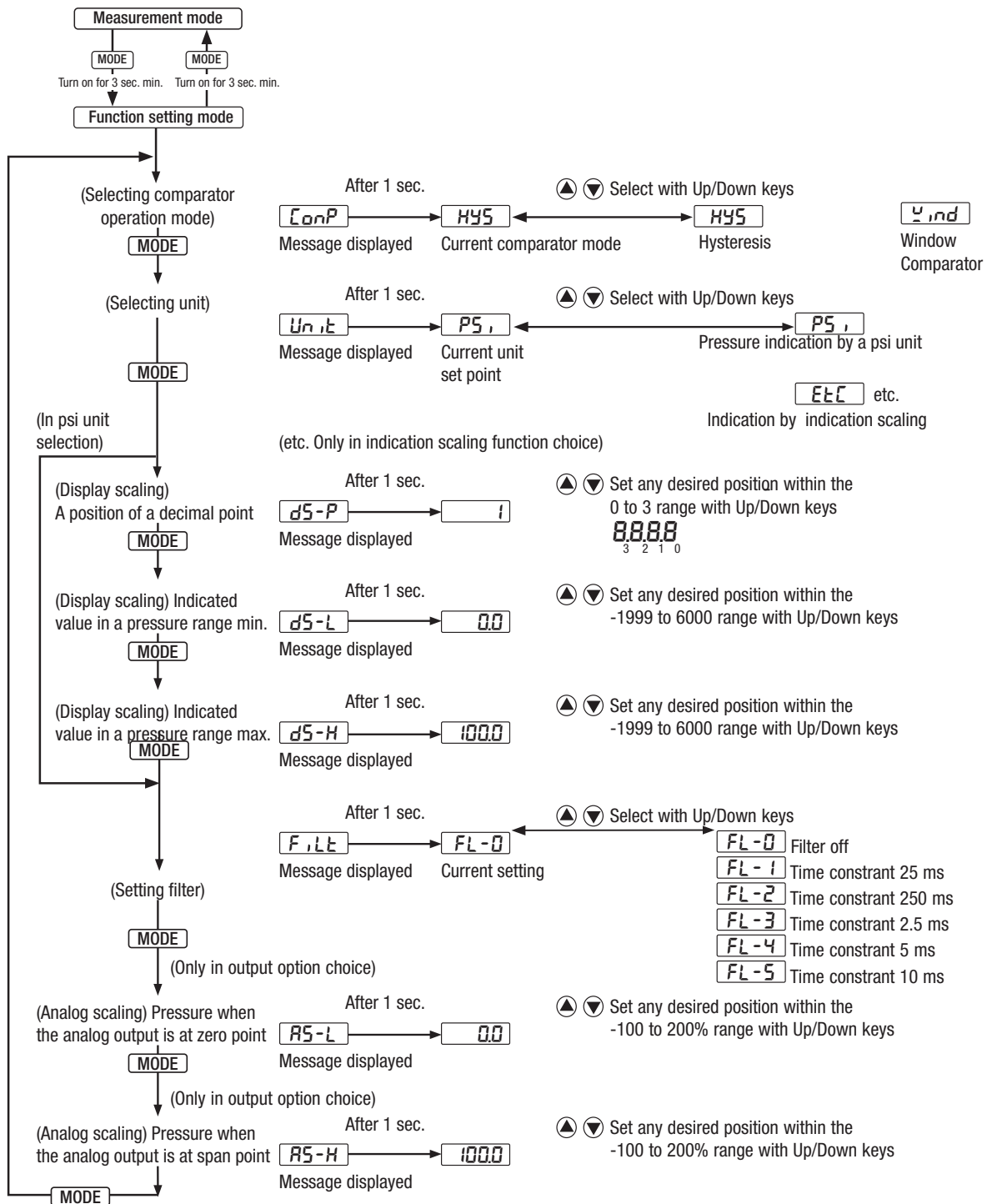

Installation and Maintenance Instructions for ZT60 High Purity Pressure Transmitter with Display



9.3 Selecting Comparator Operation Mode

Select "Selecting Comparator Operation Mode" with the **MODE** key. The message **ConP** is displayed for one second and then the current operation mode is displayed. Select either Hysteresis or Window Comparator Operation with the Up/Down keys.

9.4 Selecting Pressure Unit

Select "Selecting Unit" with the **MODE** key. The message **Unit** is displayed for one second and then the current unit is displayed. Select the unit with the UP/DOWN key. When the operator selects [EtC], the LED display is scaled by the value set in the display scaling. The analog output is not scaled.

Pressure range and display unit chart.

Pressure Range Code	Pressure Range Min/Max	mmHg	kPa	psi	kgf/cm2	Bar	mHg	MPa
V/15#	Vac to 15 psi	776	103.4	15.00	1.055	1.034	—	—
V/30#	Vac to 30 psi	1552	206.8	30.0	2.109	2.068	—	—
V/45#	Vac to 45 psi	—	310	45.0	3.16	3.10	2.327	—
V/75#	Vac to 75 psi	—	—	75.0	5.27	5.17	3.88	0.517
V/150#	Vac to 150 psi	—	—	150.0	10.55	10.34	7.76	1.034
V/300#	Vac to 300 psi	—	—	300	21.09	20.68	15.52	2.068
30#	0 to 30 psi	1552	206.8	30.0	2.109	2.068	—	—
45#	0 to 45 psi	—	310	45.0	3.16	3.10	2.327	—
75#	0 to 75 psi	—	—	75.0	5.27	5.17	3.88	0.517
150#	0 to 150 psi	—	—	150.0	10.55	10.34	7.76	1.034
300#	0 to 300 psi	—	—	300	21.09	20.68	15.52	2.068
500#	0 to 500 psi	—	—	500	35.2	34.5	25.86	3.45
750#	0 to 750 psi	—	—	750	52.7	51.7	38.8	5.17
1500#	0 to 1500 psi	—	—	1500	105.5	103.4	77.6	10.34
3000#	0 to 3000 psi	—	—	3000	210.9	206.8	155.2	20.68
N100/100KP	(-) 100 to 100 kPa	750	100	14.50	1.020	1.000	—	—
N100/200KP	(-) 100 to 200 kPa	1500	200	29.01	2.039	2.000	—	—
N100/300KP	(-) 100 to 300 kPa	—	300	43.5	3.06	3.00	2.250	—
NP1/P5MP	(-) 0.1 to 0.5 MPa	—	—	72.5	5.10	5.00	3.75	0.500
NP1/1MP	(-) 0.1 to 1 MPa	—	—	145.0	10.20	10.00	7.50	1.000
NP1/2MP	(-) 0.1 to 2 MPa	—	—	290.1	20.39	20.00	15.00	2.000
200KP	0 to 200 kPa	1500	200	29.01	2.039	2.000	—	—
300KP	0 to 300 kPa	—	300	43.5	3.06	3.00	2.250	—
P5MP	0 to 0.5 MPa	—	—	72.5	5.10	5.00	3.75	0.500
1MP	0 to 1 MPa	—	—	145.0	10.20	10.00	7.50	1.000
2MP	0 to 2 MPa	—	—	290.1	20.39	20.00	15.00	2.000
3.5MP	0 to 3.5 MPa	—	—	508	35.7	35.0	26.25	3.50
5MP	0 to 5 MPa	—	—	725	51.0	50.0	37.5	5.00
10MP	0 to 10 MPa	—	—	1450	102.0	100.0	75.0	10.00
20MP	0 to 20 MPa	—	—	2901	203.9	200.0	150.0	20.00
N1/1BR	(-) 1 to 1 Bar	750	100	14.50	1.020	1.000	—	—
N1/2BR	(-) 1 to 2 Bar	1500	200	29.01	2.039	2.000	—	—
N1/3BR	(-) 1 to 3 Bar	—	300	43.5	3.06	3.00	2.250	—
N1/5BR	(-) 1 to 5 Bar	—	—	72.5	5.10	5.00	3.75	0.500
N1/10BR	(-) 1 to 10 Bar	—	—	145.0	10.20	10.00	7.50	1.000
N1/20BR	(-) 1 to 20 Bar	—	—	290.1	20.39	20.00	15.00	2.000
2BR	0 to 2 Bar	1500	200	29.01	2.039	2.000	—	—
3BR	0 to 3 Bar	—	300	43.5	3.06	3.00	2.250	—
5BR	0 to 5 Bar	—	—	72.5	5.10	5.00	3.75	0.500
10BR	0 to 10 Bar	—	—	145.0	10.20	10.00	7.50	1.000
20BR	0 to 20 Bar	—	—	290.1	20.39	20.00	15.00	2.000
35BR	0 to 35 Bar	—	—	508	35.7	35.0	26.25	3.50
50BR	0 to 50 Bar	—	—	725	51.0	50.0	37.5	5.00
100BR	0 to 100 Bar	—	—	1450	102.0	100.0	75.0	10.00
200BR	0 to 200 Bar	—	—	2901	203.9	200.0	150.0	20.00

9.5 Scaling LED Display

When the operator selects **[EEL]** in the selection of unit, the LED value for applied pressure is scaled to any desired value. This function is used to scale the LED display value for min/max pressure range within the range of -1999 to 6000 on the digital display..

Select “Display Scaling” with the **[MODE]** key. The message **[d5-P]** is displayed for one second and then the decimal position for the current pressure Indication is displayed. Change the value with the Up/Down keys.

Set the display value for min. and max. pressure range in like manner using the **[MODE]** and Up/Down keys.

The display value for the min./max. pressure range is stored internally as arithmetic coefficients. From this time on, whenever you select the unit **[EEL]**, the value is scaled by this coefficient and LED displayed.

Example: The 0.0 to 75.0 psi indication for pressure range 0 to 75 psi (0 to 100%F.S.) is changed to the 0 to 100 indication.

- [d5-P]** Position of decimal point
(from the least digit) 1 → 0
- [d5-L]** Indication value for minimum
pressure range 0 → 0
- [d5-H]** Indication value for maximum
pressure range 75 → 100

9.6 Setting Filter

The ZT60 transmitter incorporates a digital filter with five time constants. Use the filter when pressure changes considerably, making it difficult to read the indication. The selected filter will be reflected in the comparator and analog output.

Select “Setting Filter” with the **[MODE]** key. **[FiL]** message is displayed for one second and then the current setting is displayed. Select a new filter time constant with the Up/Down keys.

- [FL 0]** No filter
- [FL 1]** 25 ms time constant
- [FL 2]** 250 ms time constant
- [FL 3]** 2.5 s time constant
- [FL 4]** 5 s time constant
- [FL 5]** 10 s time constant

9.7 Scaling Analog Output (for units with optional Analog Output)

This mode is used to set a pressure corresponding to analog output zero point (4 mADC, or 1 VDC)/span point 20 mADC or 5 VDC).

Select “Analog Scaling” with the **[MODE]** key. A message **[R5-L]** is displayed for one second and then the pressure corresponding to the current analog output zero point (4 mADC, or 1 VDC) is displayed in a percentage of the full scale of the pressure range. Enter the desired value with the Up/Down keys.

Set the pressure for analog output span point **[R5-H]** in like manner using the **[MODE]** key and Up/Down keys.

Example: The unit of 4 to 20 mADC output with pressure range 0 to 75 psi (0 to 100%F.S.) is changed to 4 to 20 mADC output with 0 to 72.5 psi.

- [R5-L]** Pressure at analog output
zero point : 0.0%F.S. → 0.0%F.S.
(will output 4 mADC with pressure range 0%F.S.)
- [R5-H]** Pressure at analog output
span point: 100.0%F.S. → 96.7%F.S.
(20 mADC with pressure range 96.7%F.S.)

10. Comparator Operation

The comparator incorporates two points of OUT1 and OUT2. For each of them, you may collectively select and set two kinds of operation modes of “Hysteresis (upper/lower limits)” and “Window Comparator.” For both modes, you may set a maximum of two seconds of On/Off delay time for OUT1 and OUT2 individually. When the comparator output conditions are satisfied as described below, respective outputs enter into the ON state and the Monitor LED (OUT1, OUT2) is lighted.

10. 1 Procedure for Comparator Setting Mode

Press the **[MODE] key (release within three seconds) in the measurement mode to enter into the comparator setting mode. The “Set” LED flashes to confirm you are in the comparator setting mode.**

This mode is used to set operating pressure for comparator outputs. The values entered in this mode will become “A” and “b” of hysteresis and window comparator selected in the function setting mode (selection of comparator operation mode).

Installation and Maintenance Instructions for ZT60 High Purity Pressure Transmitter with Display

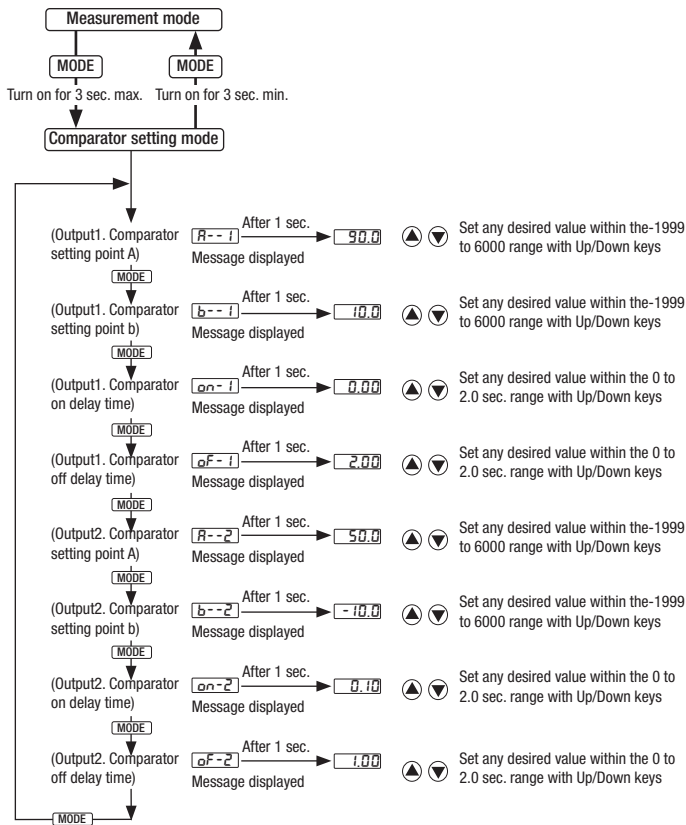

10.2 COMPARATOR OPERATION (HYSTERESIS)

• Setting the upper limit

This is the mode in which the comparator operates with the setting item (A) as the upper limit. The upper limit setting is determined when you select a positive figure (including 0) for setting item (b).

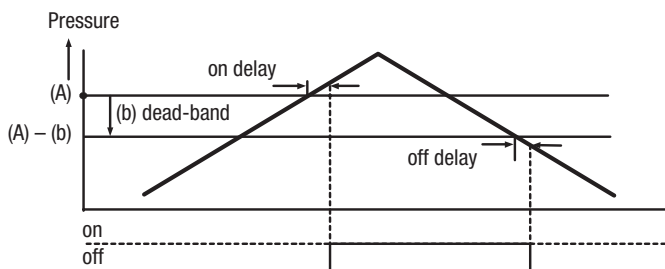

• Setting the lower limit

This is the mode in which the comparator operates with the setting item (A) as the lower limit. The lower limit setting is determined when you select a negative figure for setting item (b).

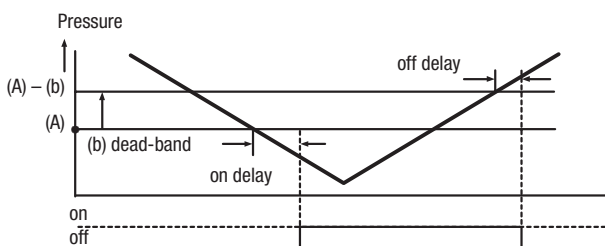

10.3 OPERATION OF WINDOW COMPARATOR

• For (A) ≤ (b)

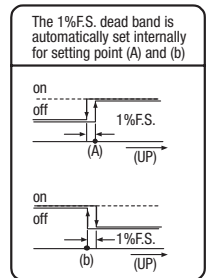
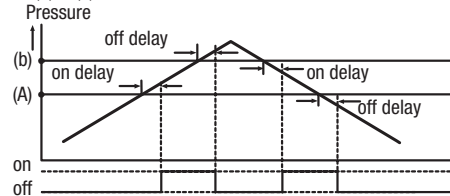

• For (A) > (b)

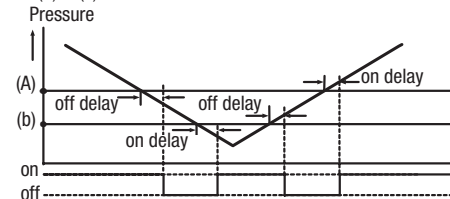

When the ON and OFF delay time is set, the delay time counting starts from where 1% F.S. of initial setting is exceeded. Accordingly the delay time will be 1% F.S. + setting delay time.

11. OTHER FUNCTIONS

• Basic Key Operations

In all setting mode, values are set with the ▲ ▼ keys. Use ▲ key to increase and ▼ key to decrease the value. Values continuously increase or decrease in three different speeds of choice when ▲ ▼ key is held for more than 0.5 seconds. ▲ ▼ keys are also used for setting comparator, unit and filter in the function setting mode.

Do not use a needle or other pointed items to operate the keys.

• Adjusting the Zero Point

Open the pressure port to atmosphere while the setting is in the measurement mode and press the [ADJ.] key for more than three seconds until the "SET" LED is flashing, then release the [ADJ] key. ZT60 will automatically adjust its zero point after approximately one second, and the indicated pressure shall be zero. [0RdJ] will be displayed when zero point adjustment is complete. An error [0Err] sign will be displayed for one second indicating that zero adjustment is incomplete, when exerted pressure is outside ± 10%F.S. of range. Before any zero adjustment, first power on the unit and warm up for 15 minutes with current applied.

• Loop Check

The operator can manually test pressure indication, analog outputs and comparator with the ▲ ▼ keys irrespective of the pressure applied. This may be used for simulation of wiring check for analog outputs, comparator outputs, etc.

Press the [MODE] key + ▼ key in the measurement mode. A message [LoOP] is indicated for one second, indicating that you have entered into the loop check mode. The "Set" LED flashes to confirm you are in measurement mode.

Installation and Maintenance Instructions for ZT60 High Purity Pressure Transmitter with Display



The operator can change the pressure indication value manually with the ▲ ▼ keys. The analog and comparator outputs also vary in accordance with the display. Press the **MODE** key for more than three seconds to return to the measurement mode.

• PeakHold

The ZT60 unit keeps the maximum and minimum pressure level applied to the pressure port as peak and bottom value, respectively, in the internal memory. The peak and bottom values are displayed as long as you press and keep pressed the ▲ and ▼ keys, respectively. When you select this operation, a message **PEAK** is displayed for one second and "SET LED" lamp flashes.

Peak and bottom values can be reset when ZT60 is re-powered up or by the following procedure:

Resetting peak value: While pressing and holding ▲ key, press ▼ key

Resetting bottom value: While pressing and holding ▼ key, press ▲ key

• KeyLock

You may nullify the key operations to prevent inadvertent overwriting of setting values.

Once the key lock is set, the function setting, comparator setting, zero point adjustment, and loop check modes cannot be accessed. The key lock cannot be re-set by re-powering ZL95. It can only be reset by the following unlocking procedure.

Press **MODE** key + ▲ key in the measurement mode. A message **LoLk** is displayed for one second, indicating that the unit has entered into the key lock state.

To reset, also press **MODE** key + ▼ key. A message **UnLk** is indicated for one second, indicating that the unit is unlocked.

• Error Indication

An error message and a measuring pressure are alternately displayed when one of the following occurs while it is in Measurement mode or Loop Check mode.

Error display	Contents	Action
FFF	A pressure equal to or above 110%F.S. of sensor range is applied OR when indicated value exceeded 6000	Reduce pressure to rated range
-FFF	A pressure equal to or above -10%F.S. of sensor range is applied OR when indicated value exceeded -1999	
DErr	When, in zero adjustment, it is pressurized pressure of ±10%F.S. range outside of pressure range	Open the unit to the atmosphere and adjust zero point again

EE-1	Comparator 1 is overloaded.	Please limit load current to 80 mADC max. To recover from an error, check the wire connections and the rating of the connected instruments and then power up the unit.
EE-2	Comparator 2 is overloaded.	
EE-12	Both Comparator 1 and 2 are overloaded.	

• Backup of set point

This has EEPROM built-in inside and maintains set point/ some active state for power interruption.

Setting values stored in memory	States stored in memory
All set point in a function setting mode and comparator setting mode	Key lock/ unlock

12. MAINTENANCE

Routine inspection should be conducted at least every 6 months with device recalibration or zero adjustment being performed as necessary. Product should only be inspected by properly trained personnel.

Routine Inspection Checklist:

- * Physical appearance (scratches, cracks, warping, corrosion etc.)
- * Insulation resistance between each terminal and case (at 100 MΩ or more/50 Vdc or less)
- * Leak test for the connection points
- * Output check by a pressure reference device and measuring instrument

13. WARRANTY

If the delivered products within the warranty period (one year from the date of manufacture) are determined to be non-conforming products according to "Defects due to the design or manufacturing", they will be repaired or replaced with conforming products free of charge. However note the following are excluded:

- (1) Where the delivered products are disassembled, altered or if its parts are replaced or a new function is added by the user or any third party.
- (2) Where directions described in the instruction manual are not followed.
- (3) Where the non-conformance is caused by deterioration due to use, natural disaster, fire or other force majeure events
- (4) The secondary damage caused by the non-conformance of the products including the above.

Returned units are subject to evaluation by Ashcroft prior to determining warranty.