

DT - Deutsch DT04-3P

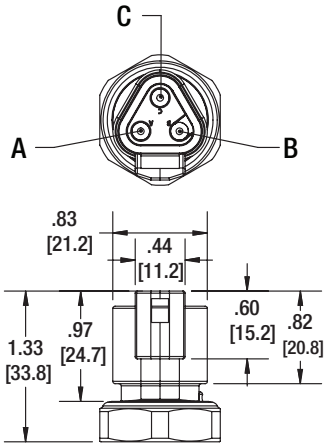

Deutsch DT04-3P		
Pin #	Voltage Function	Current Function
A	V+	V+
B	V- (Common)	V-
C	Output	V-

IP67 Ingress rating

* Use either V- termination on S1 with 4-20mA output

DU - Deutsch DT04-4P

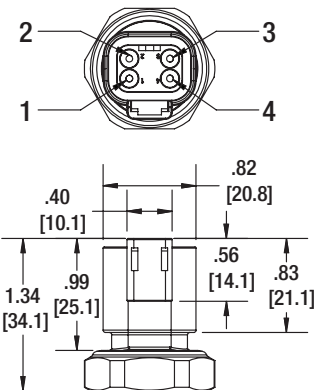

Deutsch DT04-4P		
Pin #	Voltage Function	Current Function
1	V- (Common)	V-
2	V+	V+
3	Ground	Ground
4	Output	V-

IP67 Ingress rating

* Use either V- termination on S1 with 4-20mA output

DS - Deutsch DTM04-3P

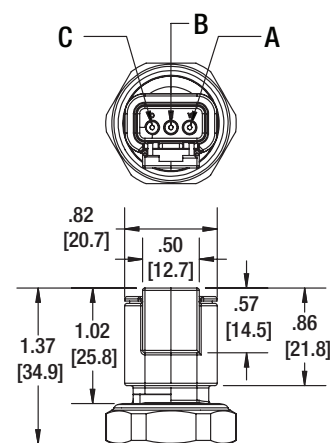

Deutsch DTM04-3P		
Pin #	Voltage Function	Current Function
A	V+	V+
B	V- (Common)	V-
C	Output	V-

IP67 Ingress rating

* Use either V- termination on S1 with 4-20mA output

GN - Metri-Pack

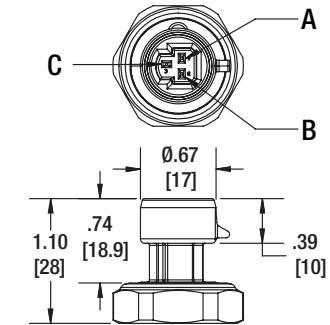

Metri-Pack		
Pin #	Voltage Function	Current Function
A	V- (Common)	V-
B	V+	V+
C	Output	V-

IP67 Ingress rating

* Use either V- termination on S1 with 4-20mA output

DC - EN17530-803 Form C (DIN 43650 Form C)

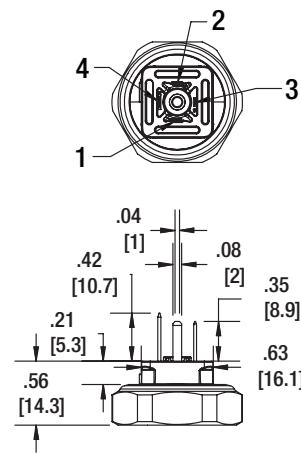

Din Form C		
Pin #	Voltage Function	Current Function
1	V+	V+
2	V- (Common)	V-
3	Output	V-
4	Ground	Ground

IP67 Ingress rating

* Use either V- termination on S1 with 4-20mA output

DA - EN17530-803 Form A (DIN 43650 Form A)

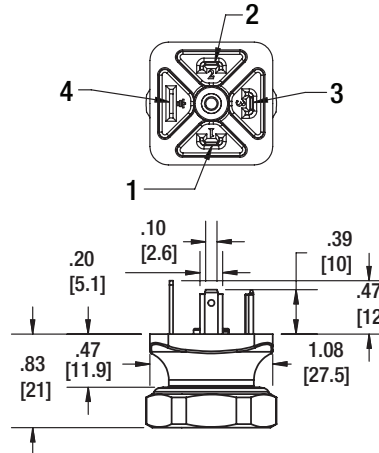

Din Form A		
Pin #	Voltage Function	Current Function
1	V+	V+
2	V- (Common)	V-
3	Output	V-
4	Ground	Ground

IP67 Ingress rating

* Use either V- termination on S1 with 4-20mA output

JN - AMP Econoseal

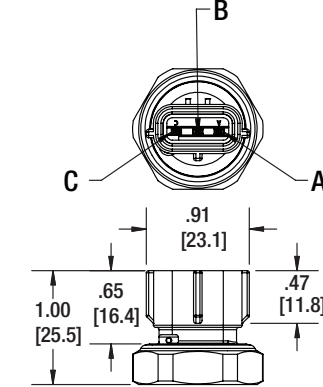

AMP Econoseal		
Pin #	Voltage Function	Current Function
A	V+	V+
B	V- (Common)	V-
C	Output	V-

IP67 Ingress rating

* Use either V- termination on S1 with 4-20mA output

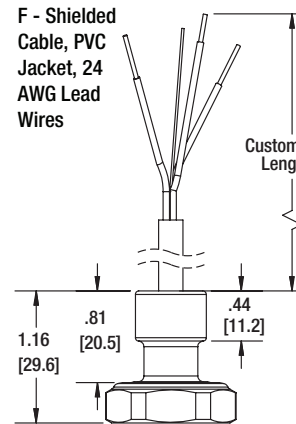

Shielded Cable		
Pin #	Voltage Function	Current Function
Red	V+	V+
Black	Common	V-
White	Output	n/a
Drain	n/a	n/a

IP67 Ingress rating

ASHCROFT®

S1 PRESSURE TRANSMITTER

INSTRUCTION SHEET

WARNING! READ BEFORE INSTALLATION

1. GENERAL:

If the S1 is used in a manner not specified by Ashcroft Inc, the protection provided by the unit may be impaired. A failure resulting in injury or damage may be caused by excessive overpressure, excessive vibration or pressure pulsation, excessive instrument temperature, corrosion of the pressure containing parts, or other misuse. Consult Ashcroft Inc., Stratford, Connecticut, USA before installing if there are any questions or concerns.

2. OVERPRESSURE:

Pressure spikes in excess of the rated overpressure capability of the transducer may cause irreversible electrical and/or mechanical damage to the pressure measuring and containing elements.

Fluid hammer and surges can destroy any pressure transducer and must always be avoided.

A pressure snubber should be installed to eliminate the damaging hammer effects. Fluid hammer occurs when a liquid flow is suddenly stopped, as with quick closing solenoid valves. Surges occur when flow is suddenly begun, as when a pump is turned on at full power or a valve is quickly opened.

Liquid surges are particularly damaging to pressure transducers if the pipe is originally empty. To avoid damaging surges, fluid lines should remain full (if possible), pumps should be brought up to power slowly, and valves opened slowly. To avoid damage from both fluid hammer and surges, a surge chamber should be installed.

Symptoms of fluid hammer and surge's damaging effects:

- Pressure transducer exhibits an output at zero pressure (large zero offset).
- Pressure transducer output remains constant regardless of pressure
- In severe cases, there will be no output.

FREEZING:

Prohibit freezing of media in pressure port. Unit should be drained (mount in vertical position with electrical termination upward) to prevent possible overpressure damage from frozen media.

3. STATIC ELECTRICAL CHARGES:

Any electrical device may be susceptible to damage when exposed to static electrical charges. To avoid damage to the transducer observe the following:

- Ground the body of the transducer BEFORE making any electrical connections.

- When disconnecting, remove the ground LAST!

Note: The shield and drain wire in the cable (if supplied) is not connected to the transducer body, and is not a suitable ground.

DESCRIPTION

The Ashcroft Model S1 pressure transducers are high performance instruments intended for use in industrial applications where the process media is compatible with the 17-4PH Stainless steel sensor material and either the 304 Stainless steel, carbon steel, brass or aluminum process connection depending on which option is used.

MECHANICAL INSTALLATION

Environmental

The S1 pressure transducer can be stored and used within the temperature limits of -40 °C to 125 °C (-40 °F to 257 °F). Ingress protection ratings of the units are dependent on the electrical termination specified. Refer to the wiring diagrams on the reverse for the IP rating of the unit which is being installed.

Mounting

The S1 pressure transducers require no special mounting hardware and can be mounted in any orientation with negligible position error. Although the units can withstand considerable vibration without damage or significant output effects, it is always good practice to mount the transducer where there is minimum vibration. For units with NPT type pressure fittings apply sealing tape or an equivalent sealant to the threads before installing. When installing or removing the unit apply a wrench to the hex wrench flats, located above the pressure fitting.

DO NOT tighten by using a pipe wrench on the housing. A 27mm (1 1/8") wrench can be used on the wrench flats of the hex.

Electro-Magnetic Interference

The circuitry of the S1 pressure transducers is designed to minimize the effect of electromagnetic and radio frequency interference. To minimize susceptibility to noise, avoid running the termination wiring in a conduit which contains high current AC power cables. Where possible avoid running the termination wiring near inductive equipment.

Field Adjustments

The S1 pressure transducers are precisely calibrated and temperature compensated at the factory to ensure long and stable performance. There are no field accessible adjustments on the transducers.

Note:

All IP ratings listed have been self-certified by Ashcroft Inc.

S1 ELECTRICAL INSTALLATION

Wiring Diagrams

(see following pages for further detail)

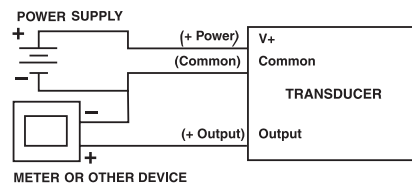
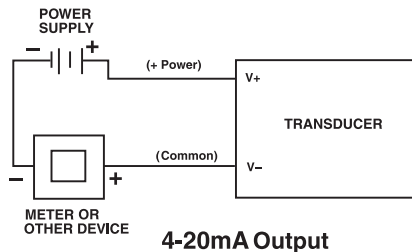

Power Supply Requirements:

Output Signal	Min Supply	Max Supply
Ratiometric* (0.5 V to 4.5 V)	4.5 Vdc	5.5 Vdc
0-5 Vdc	9 Vdc	32 Vdc
1-5 Vdc	9 Vdc	32 Vdc
1-6 Vdc	9 Vdc	32 Vdc
0-10 V	14 Vdc	32 Vdc
0.5-4.5 Vdc	9 Vdc	32 Vdc
4-20 mA**	9 Vdc	32 Vdc

*0.5 Vdc-4.5 Vdc output is ratiometric to the nominal 5 Vdc supply

**For transmitters with 4-20 mA output signal, the minimum voltage at the terminals is 9 Vdc. However, the minimum supply voltage should be calculated using the adjacent graph and formula.

S1 ELECTRICAL INSTALLATION (cont.)

Power Supply Voltage vs Loop Resistance

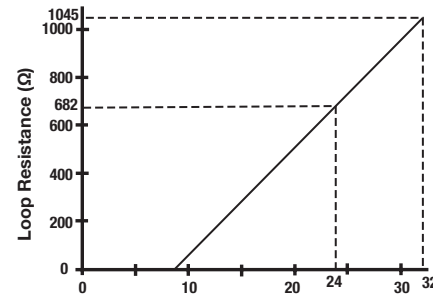

$$V_{MIN} = 9V + [0.022A \times (R_L)]$$

(*Includes a 10% safety factor)

$$R_L = R_S + R_W$$

R_L = Loop Resistance (Ohms)
R_S = Sense Resistance (Ohms)

4. MEDIA COMPATABILITY & GALVANIC COMPATIBILITY

All configurations of the S1 that utilize housing/fitting materials including zinc plated carbon steel, brass and aluminum are dissimilar to the 17-4PH Stainless steel sensor element. Both the housing/fitting material and the sensor element are in direct contact with the process media. If the process media is an electrolytic solution, galvanic corrosion may occur. Selected materials should be carefully reviewed by the user of this product for both individual chemical compatibility with the process media, as well as combined use to avoid galvanic corrosion.

For additional guidance on dissimilar metals in electrolytic solutions, please reference:

MIL-STD-889C

“Department of Defense Standard Practice, Dissimilar Metals”

Baboian, Robert.

“Galvanic Corrosion.” ASM Handbook: Volume 13A: Corrosion: Fundamentals, Testing and Protection, ASM International, Materials Park, Ohio, 2003, pp. 210–213.

** Where shielded wiring is being used; Connect the drainwire to the guard terminal on the read out device or measuring instrument if available. In all other cases connect to the ground of the power supply negative terminal.

S1 ELECTRICAL TERMINATIONS AND WIRING

EW - M12 (4 Pin) Molded Thread (Pin 3 Common)

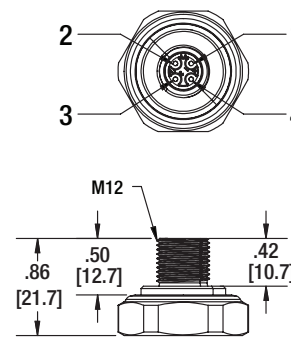

M12-4P Plastic Pin-out Type 1		
Pin #	Voltage Function	Current Function
1	V+	V+
2	Ground	Ground
3	V- (Common)	V-
4	Output	V-

IP67 Ingress rating

* Use either V- termination on S1 with 4-20mA output

RW - M12 (4 Pin) Molded Thread (Pin 4 Common)

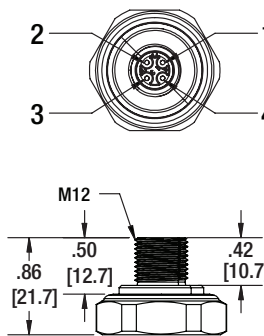

M12-4P Plastic Pin-out Type 2		
Pin #	Voltage Function	Current Function
1	V+	V+
2	Output	V-
3	Ground	Ground
4	V- (Common)	V-

IP67 Ingress rating

* Use either V- termination on S1 with 4-20mA output

S1 ELECTRICAL TERMINATIONS AND WIRING

EX - M12 (4 Pin) Metal Thread (Pin 3 Common)

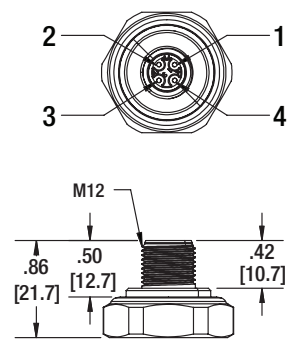

M12-4P Metal Pin-out Type 1		
Pin #	Voltage Function	Current Function
1	V+	V+
2	Ground	Ground
3	V- (Common)	V-
4	Output	V-

IP67 Ingress rating

* Use either V- termination on S1 with 4-20mA output

RX - M12 (4 Pin) Metal Thread (Pin 4 Common)

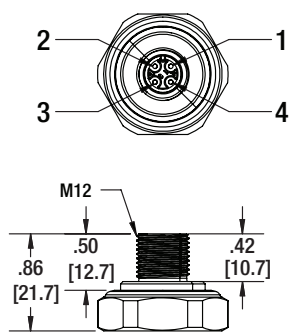

M12-4P Metal Pin-out Type 2		
Pin #	Voltage Function	Current Function
1	V+	V+
2	Output	V-
3	Ground	Ground
4	V- (Common)	V-

IP67 Ingress rating

* Use either V- termination on S1 with 4-20mA output