

**Installation Instructions
for ASHCROFT® 8009S
Pressure Gauge**



Applicable Standards:

- EN 837-1 Bourdon tube pressure gauges, dimensions, metrology, requirements and testing.
- EN 837-2 Selection and installation recommendations for pressure gauges.
- ASME B40.100 Pressure gauges and gauge attachments
- 2014/68/EC Pressure equipment directive.

Specifications: Refer to Ashcroft Type 8009S data sheets at www.ashcroft.com

1. SAFETY



WARNING!

Before installation, be certain the appropriate gauge has been selected considering operating pressure/full scale pressure/proof pressure, wetted material requirements, media compatibility, operating temperature, vibration, pulsation, desired accuracy and any other gauge component related to the service application (including the potential need for protective attachments and/or special installation requirements). Failure to do so could result in equipment damage, gauge failure and/or personal injury. Only qualified personnel should be permitted to install and maintain pressure gauges.

2. INSTALLATION

When installing the gauge connection into the application, use the wrench area (above the threaded portion) to thread in and tighten the gauge. Do not use the gauge case to install the gauge. This could result in loss of accuracy, excessive friction, or mechanical damage to the pressure element or gauge case.

The gauge connection must be compatible with the mating connection and must be assembled appropriately. If the mating parts do not seal completely, a sealing material may be considered. Install with open end wrench;

Gauge Size	8009S
63 mm	7/16" (11 mm)
100 mm	5/8" (16 mm)

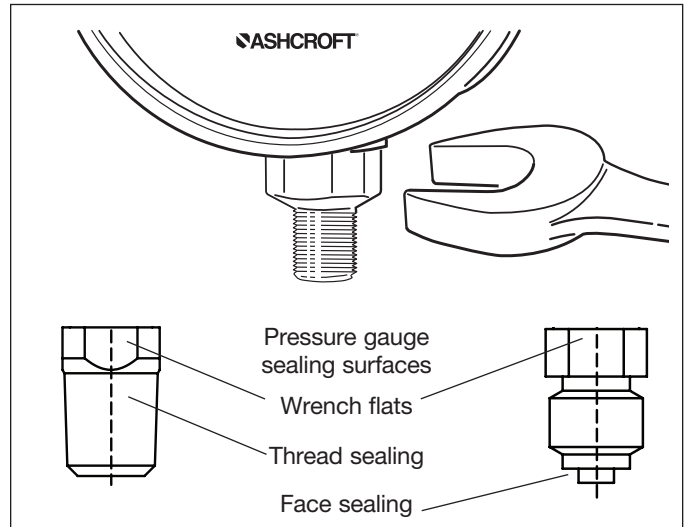

After installation, pull up the blue cap on the fill/vent plug to the full open position. Opening the vent plug will relieve internal pressure changes in the gauge case that otherwise would have been induced by environmental changes in pressure and/or temperature. Without being vented this change in internal pressure could adversely affect the accuracy of the gauge. If liquid filled, only open vent plugs when the plug is oriented in the vertical position.

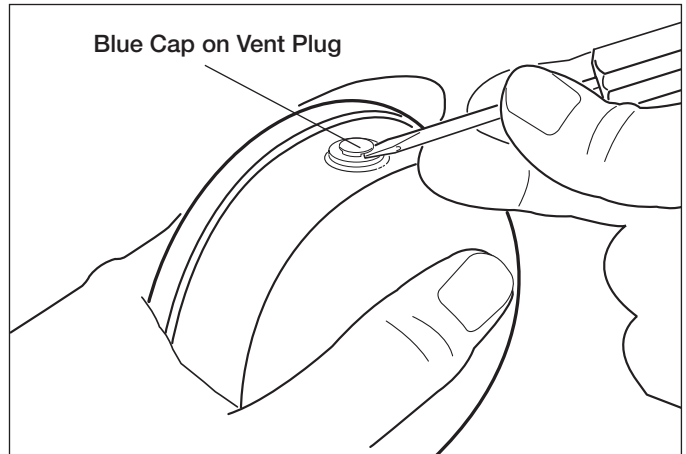

3. STORAGE

Gauge should remain in original packaging until installation. This will protect from mechanical damage as well as environmental conditions. Storage temperature range:
8009S: Liquid Filled -40 °F to 158 °F (-40 °C to 70 °C)
8009S: Dry -40 °F to 250 °F (-40 °C to 121 °C).

4. MAINTENANCE/REPAIRS

Check regularly to ensure the gauge is in good working order. When removing the gauge from the application make sure there is no pressure in the system and all system media has been isolated from the gauge. If gauge is damaged or out of calibration a new gauge must be installed. Misuse or misapplication of this gauge could result in gauge failure, equipment damage and/or personal injury.

5. AVAILABLE MOUNTING OPTIONS

Installation Instructions Type 8009 Front Flange Mounting Kit

100 mm displayed

1. Align any screw hole with gauge fill plug and press flange onto back of case until it touches front ring. (Fill plug should slightly compress to allow flange to slide over it). To prevent warping, press evenly around perimeter of flange as it slides down the case.
2. Drill panel hole for gauge, and drill 3 clearance OR tapped holes (120° apart) for mounting screws (see table for sizes).
3. Use hardware provided to secure gauge to panel.

NOTE: Use an open end wrench on the gauge process connection when connecting gauge to pressure source.

Gauge Size	Kit Part No.	Panel Hole		Bolt Circle	Screw	
		Min	Max		Clearance	Tap Hole/Thread Size
63 mm	101A230-11	2.64" (67.0 mm)	2.76" (70.0 mm)	3.13" (79.5 mm)	0.150" (3.8 mm)	0.1065"/#6-32 UNC
100 mm	101A230-102	4.04" (102.5 mm)	4.15" (105.4 mm)	4.65" (118 mm)	0.201" (5.1 mm)	0.159"/#10-32 UNF

Installation Instructions Type 8009 U-Clamp Connection Mounting Kit

1. Drill panel hole for gauge (see table for sizes).
2. Place gauge through panel. Assemble bracket onto process connection using square keyway, then shift bracket to engage into groove of process connection.
3. Install screws (provided) through bracket and tighten onto panel until gauge is secure (5 -7 in-lbs).

NOTE: Use an open end wrench on the gauge process connection when connecting gauge to pressure source.

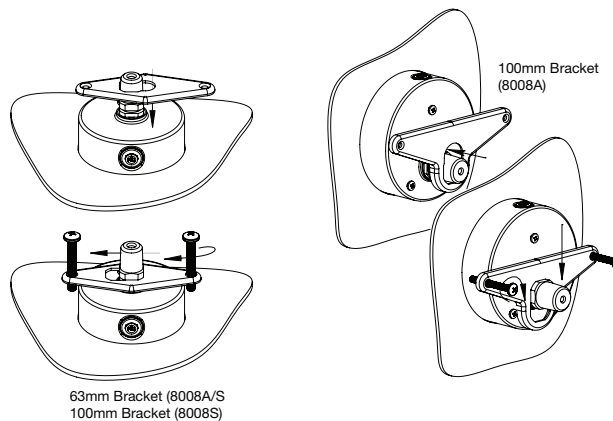

Gauge Size	Gauge Model No.	Kit Part No.	Panel Hole	
			Min.	Max.
63 mm	8009S	101A230-631	2.48" (63.0 mm)	2.56" (65.0 mm)
100 mm	8009S	101A230-1010S	3.94" (100.0 mm)	4.02" (102.0 mm)

Installation Instructions Type 8009 Rear Flange Mounting Kit

1. Place rear flange on back of gauge and secure it in place with the short pan-head screws provided. (Tighten to 10 -16 in-lbs).
2. Drill 3 clearance OR tapped holes in panel (120° apart) for mounting screws (see table for sizes and locations).
3. Use remaining hardware provided to secure gauge to panel.

NOTE: Use an open end wrench on the gauge process connection when connecting gauge to pressure source.

Gauge Size	Kit Part No.	Bolt Circle	Panel Hole	
			Clearance	Tap Hole/Thread
63 mm	101A230-633	3.13" (79.5 mm)	0.150" (3.8 mm)	0.1065"/#6-32 UNC
100 mm	101A230-103	4.57" (116.0 mm)	0.201" (5.1 mm)	0.159"/#10-32 UNF

5. AVAILABLE MOUNTING OPTIONS (Cont'd)

Installation Instructions Type 8009 U-Clamp Case Mounting Kit

1. Drill panel hole for gauge (see table for sizes).
2. Install threaded studs (provided) onto back of gauge (finger tight).
3. Place gauge through panel. Assemble bracket onto threaded studs and secure against panel
4. Install locking nuts (provided) onto threaded and tighten until gauge is secure (16 – 20 in-lbs).

NOTE: Use an open end wrench on the gauge process connection when connecting gauge to pressure source.

Gauge Size	Kit Part No.	Panel Hole	
		Min.	Max.
63 mm	101A230-636	2.48" (63.0 mm)	2.56" (65.0 mm)
100 mm	101A230-106	3.94" (100 mm)	4.02" (102.0 mm)

Installation Instructions Type 8009 Trim Ring

1. Press trim ring onto back of case until it touches the front ring. (Fill plug should slightly compress to allow trim ring to slide over it. To prevent warping, press evenly around perimeter of trim ring as it slides down the case.)
2. Drill panel hole for gauge (see table for sizes).
3. Mount gauge to panel with secondary clamp kit.
NOTE - if no other mounting kit is purchased, gauge must be mounted by 'hard plumbing' (not recommended)

NOTE: Use an open end wrench on the gauge process connection when connecting gauge to pressure source.

Gauge Size	Kit Part No.	Panel Hole	
		Min.	Max.
63 mm	101A230-637	2.56" (65.0 mm)	2.70" (68.8 mm)
100 mm	101A230-107	4.04" (102.5 mm)	4.15" (105.4 mm)

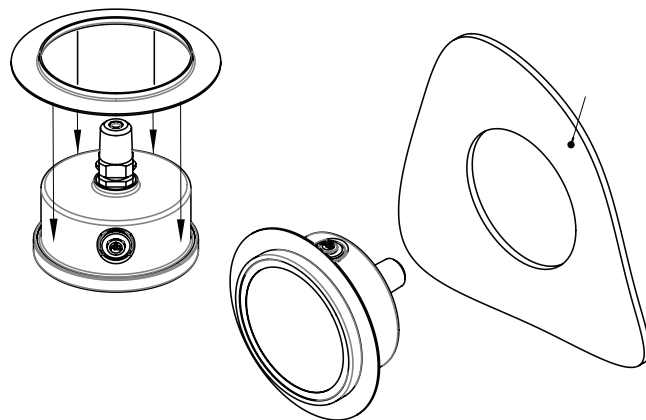

6. CALIBRATION INSTRUCTIONS

Calibration

Inspect gauge for accuracy. At times gauges are simply “off zero” and opening the ventable plug at the top of the gauge will relieve internal gauge pressure and correct the offset. If this is not adequate and inspection shows that the gauge warrants recalibration to correct zero, span and/or linearity errors, follow the instructions below.

Positive Pressures

1. Adjust pointer with a slotted screwdriver until it is in the center of the zero box. This is often all that is required to correct calibration issues.
2. Apply full scale pressure. If error exceeds span accuracy adjust pointer until gauge is within tolerance. Clockwise rotation moves pointer clockwise, counter-clockwise rotation moves the pointer counterclockwise.
3. Fully exhaust pressure and check that pointer still is still in the zero box. If not, repeat step 1 and 2.
4. Once 0 and full scale are within tolerance, pressurize gauge to mid-scale.
5. If gauge is within span accuracy, calibration is complete.
6. If an adjustment was made in step 5, recheck the gauge at zero and full scale, adjust accordingly until zero, mid and full scale points are in tolerance.

Vacuum Range

1. Adjust pointer until it is in the center of the zero box. This is often all that is required to correct calibration issues.
2. Apply 25 inches Hg vacuum. If the error exceeds span accuracy adjust pointer until gauge is within tolerance.
3. Vent to 0 pressure and check pointer position in the zero box. If error exceeds span accuracy rotate the pointer. Clockwise rotation moves pointer clockwise, counter-clockwise rotation moves the pointer counterclockwise.
4. Repeat step 1 and 2 until 0 and 25 inches of Hg are within gauge tolerance.
5. Apply 15 inches Hg vacuum. If gauge is within span accuracy, calibration is complete.
6. If an adjustment was made in step 4, recheck the gauge at zero and 25 inches of Hg vacuum, adjust accordingly until zero, 15 and 25 inches Hg are in tolerance.
7. Continue below.

Re-assemble window and ring to gauge:

- a. Reinstall insert into ring, followed by window and gasket. Ensure that the gasket is seated properly under all four tabs of the ring and does not wrinkle when ring is tightened.

Note: Tighten ring:

- 63 mm: Apply 100-125 inlbs of torque.
- 100mm: Apply 200-225 inlbs of torque.

Warning: Over tightening of safety glass may induce cracking.