

Installation and Maintenance Instruction Manual



Differential pressure gauge, model P5500 and P6500

for explosion risk areas in European Union pursuant to Directive 2014/34/EU (ATEX)

In the following configuration:

- ###P5500/P6500###ATEX diaphragm pressure gauge without switching contact
- ###P5500/P6500###I#####ATEX diaphragm pressure gauge with inductive proximity switches



Table of contents:

1	General remarks.....	4
1.1	Purpose of this Manual.....	4
1.2	Symbols.....	4
1.3	Limits of liability.....	4
1.4	Copyright.....	4
1.5	Warranty.....	4
1.6	Manufacturer's address, customer services.....	4
2	Safety.....	5
2.1	General sources of hazards.....	5
2.2	Use in accordance with intended purpose.....	5
2.3	Operator's responsibility.....	5
2.4	Staff qualifications (target group assessment).....	5
2.5	Signs/Safety markings.....	5
2.6	Safety equipment.....	6
2.7	Environmental protection.....	6
3	Use in potentially explosive atmospheres according to Directive 2014/34/EU (ATEX) & Regulation SI 2016, No. 1107.....	6
3.1	P5500 and P6500 without switching contact.....	6
3.2	P5500 I#### and P6500 I#### with inductive proximity switches SJ2-N.....	7
4	Technical data.....	8
5	Marking of the device.....	8
6	Construction and function.....	9
6.1	Overview.....	9
6.2	Description of function.....	9
6.1	Description of components.....	9
6.2	Accessories.....	10
7	Transport.....	10
7.1	Safety.....	10
7.2	Transport inspection.....	10
7.3	Storage.....	10
8	Assembly/Installation.....	10
8.1	Safety.....	10
8.2	Preparations (requirements for the installation location).....	10
8.3	Mounting/Installation.....	11
8.4	Starting up.....	11
8.5	Subsequent relocation of the gauge (by the customer).....	12
9	Servicing.....	12
9.1	Safety.....	12
9.2	Check on function, and recalibration.....	13
9.3	Cleaning and maintenance.....	13
10	Faults.....	13
10.1	Safety.....	13
10.2	Conduct in the event of faults.....	13
10.3	Fault table.....	13

10.4	Conduct following fault rectification	13
11	Removal, disposal.....	14
11.1	Safety.....	14
11.2	Removal.....	14
11.3	Disposal	14
12	Appendix	14
12.1	Data Sheet Differential Pressure Gauge P5500 / P6500	14
12.2	EU Declaration of conformity model P5500 and P6500	15
12.3	EU Declaration of conformity model P5500 and P6500 with contacts	16
12.4	UK Declaration of conformity model P5500 and P6500	16
12.5	UK Declaration of conformity model P5500 and P6500 with contacts Fehler! Textmarke nicht definiert.	

1 General remarks

The differential pressure gauge described in these operating instructions is designed using the latest standards, guidelines and findings. During the manufacturing processes, all components are subject to our high quality and environmental criteria. For this purpose, we maintain certified management systems according to ISO 9001 and ISO 14001. For the special requirements of devices for intended use in potentially explosive atmospheres, we maintain a management system according to ISO 80079-34.

1.1 Purpose of this Manual

These operating instructions contain basic instructions that must be followed for the installation, operation and maintenance of the device. It must be read by the installer, the operator and the specialist personnel responsible for the device before the device is installed and commissioned. These operating instructions must always be available at the place of use.

The following sections on general safety instructions 2 as well as the following special instructions on intended use 2.2 to disposal 11.2 contain important safety instructions, the non-observance of which may cause health and safety hazards to people, in particular to workers, and possibly to domestic and farm animals, as well as property.

1.2 Symbols



Warning!

This indicates a possibly hazardous situation where failing to follow advice may result in risks to people, animals, the environment and buildings.



Information!

This emphasizes key information for efficient, fault-free operation.

1.3 Limits of liability

Failure to respect this safety information, the envisaged uses or the limit values relating to use indicated in the technical data for the device may result in risk or to injury to people, the environment or the plant.

Claims for compensation for damage against the device supplier are excluded in such an eventuality.

1.4 Copyright

This Operating Manual may only be copied and passed on as a complete document without the special permission of the publisher.

1.5 Warranty

For the product described here, we offer a warranty pursuant to Section 6 Guarantee in Respect of Defects in our General Terms and Conditions of Delivery and Payment.

1.6 Manufacturer's address, customer services

Ashcroft Instruments GmbH

Max-Planck-Straße 1-9

D-52477 Alsdorf, Germany

Tel.: +49 (0) 2404/5589-888

E-mail: customer.service@ashcroft.com

Web: www.ashcroft.eu

2 Safety

2.1 General sources of hazards

Pressure gauges are pressurized parts where failure can result in hazardous situations. The selection of pressure gauge should be made in accordance with the rules set out in EN 837-2.

2.2 Use in accordance with intended purpose

The devices are only to be used for the intended purpose as described by the manufacturer.

The devices are used for direct display of differential pressure.

The integrated switching elements are inductive proximity switches with a groove design, supplied by isolating switch amplifiers with certified intrinsically safe power circuits. If the set limit values are exceeded, the output circuits are opened or closed.

For each use scenario, the corresponding set-up regulations must be respected. If used in explosion risk areas, the following conditions are to be respected for the individual finishes.

2.3 Operator's responsibility

Safety instructions for proper operation of the device must be respected. They are to be provided by the operator for use by the respective personnel for installation, servicing, inspection and operation. Risks from electrical energy and from the released energy of the medium, from escaping media and from improper connection of the device must be eliminated. The details for this are to be found in the corresponding applicable set of regulations, such as DIN EN, UVV (accident prevention regulations) and in sector-specific instances of use (DVWG, Ex-. GL, etc.) the VDE guidelines and the regulations supplied by local utilities companies.

The device must be taken out of service and secured against inadvertently being restarted, if the presumption is that risk-free operation is no longer possible (see Chapter 10: Faults).



Conversion works or other technical alterations to the device by the customer will violate the approval for hazardous area and are not permitted. This also applies to installation of spare parts. Possible conversions or alterations may only be carried out by the manufacturer.

The operational safety of the device is only guaranteed where it is used for its intended purpose. The specification of the device must be adapted to the medium used in the plant. The limit values indicated in the technical data must not be exceeded.

The safety information detailed in this Operating Manual, existing national regulations for accident prevention, and the operator's internal regulations regarding working, operations and safety must be respected.

The operator is responsible for all specified servicing, inspection and installation works being carried out by authorized and qualified specialists.

The operator is responsible that the device is used in the correct ATEX zone.

2.4 Staff qualifications (target group assessment)

The device may only be installed and commissioned by trained specialist personnel.

Specialized personnel are persons who are able to perform the work assigned to them due to their specialized training, experience and knowledge of the country-specific regulations, applicable standards and guidelines. For explosion-protected devices, the personnel must be trained or instructed or authorized to work on explosion-protected devices in hazardous areas.

2.5 Signs/Safety markings

The pressure gauge and its surrounding packaging carry markings. These markings show the article number, measurement range and manufacturer. The pressure gauge can be provided with additional signs and safety markings advising on special conditions:

- Advice on the filling liquid
- Advice on calibration
- Ex (for ATEX configuration)
- Oil-can deleted (if oxygen is used)

2.6 Safety equipment

This device is constructed with separate pressure chambers and case for display and can be considered as solid front safety design. For a description, please refer to Chapter 6.2. The window uses multi-layer safety glass.

2.7 Environmental protection

This device may optionally contain a filling liquid (e.g. glycerin or silicone oil). The provisions set out in the REACH regulation on production and use of chemicals are to be respected, and the relevant safety data sheets from the manufacturers of the chemicals are available on our website for download.

3 Use in potentially explosive atmospheres according to Directive 2014/34/EU (ATEX)

3.1 P5500 and P6500 without switching contact

Area of use:

Explosion risk areas Zone 1 and 2, and 21 and 22, risk from gases and dry dust

Permitted temperatures:

The maximum occurring surface temperature of 95 °C was determined with no covering of dust and with no safety factor.

For dust clouds and dust layers the ignition temperature must be specified pursuant to ISO / IEC 80079-20-2

- For dust clouds the maximum allowable medium temperature inside of the measuring instrument must not exceed 2/3 of the dust ignition temperature
- For dust layer the maximum allowable medium temperature inside of the measuring instrument must be 75K lower than the dust ignition temperature

Permitted ambient temperature -20°C to +60 °C.

Permitted medium temperature in the pressure gauge < 85 °C.

Permitted environment air with usual oxygen content (21%), ambient pressure 80 kPa (0,8 bar) to 110 kPa (1,1 bar)



Warning! With gaseous media, the device temperature may increase due to compression heat. In such cases, the rate of the pressure change must be regulated or the permitted temperature of the measuring medium reduced.

Note:

For a change in differential pressure between 10 % and 90 % of the measuring range and a pulse frequency of < 0.06 Hz, the temperature increase is <10 K.

To avoid additional temperature increase, the devices should not be exposed to direct exposure to sunlight when in operation!

For the non-electrical part of the devices, the, EN ISO 80079-36, EN ISO 80079-37, EN 60079-0 and EN 60079-31, are applicable with regard to explosion protection. The relevant requirements of these standards are satisfied.

The documentation has been filed with TÜV-Nord-Cert NB 0044 (see Declaration of Conformity).

3.2 P5500 I#### and P6500 I#### with inductive proximity switches SJ2-N

Area of use:

Explosion risk areas Zone 1 and 2, and 21 and 22, risk from gases and dry dust.

Permitted temperatures:

The maximum occurring surface temperature of 95 °C was determined with no covering of dust and with no safety factor

For dust clouds and dust layers the ignition temperature must be specified pursuant to ISO / IEC 80079-20-2

- For dust clouds the maximum allowable medium temperature inside of the measuring instrument must not exceed 2/3 of the dust ignition temperature
- For dust layer the maximum allowable medium temperature inside of the measuring instrument must be 75K lower than the dust ignition temperature.

Permitted ambient temperature -20 °C to +60 °C.

Permitted medium temperature in the pressure gauge < 85 °C.

Permitted environment air with usual oxygen content (21%), ambient pressure 80 kPa (0,8 bar) to 110 kPa (1,1 bar)



Warning! With gaseous media, the device temperature may increase due to compression heat. In such cases, the rate of the pressure change must be regulated or the permitted temperature of the measuring medium reduced.

Note:

For a change in differential pressure between 10 % and 90 % of the measuring range and a pulse frequency of < 0.06 Hz, the temperature increase is < 10 K.

To avoid additional temperature increase, the devices should not be exposed to direct exposure to sunlight when in operation!

EU design type test certification for the installed inductive proximity switches:

PTB 99 ATEX 2219X

The integrated proximity switch is indicated on the type label/wiring diagram.

The surrounding housing has protection class IP65 as per EN 60529.



For use in explosion risk areas, the devices must be connected to certified intrinsically safe power circuits:

Max. voltage	U_{\max}	= 16 V
Max. current	I_{\max}	= 25 mA
Max. power	P_{\max}	= 64 mW

Device data (per contact):

max. internal capacitance	$C_{i\max}$	= 30 nF
max. internal inductance	$L_{i\max}$	= 100 μ H

The permitted limit values for U_i , I_i and P_i for the intrinsically safe feed power circuits depend on the proximity switch type. They are to be found in the respective EU design type test certifications.

For the non-electrical part of the devices, the standards, EN ISO 80079-36, EN ISO 80079-37, EN 60079-0 and EN 60079-31 are applicable with regard to explosion protection. The relevant requirements of these standards are satisfied.

The documentation has been filed with TÜV-Nord-Cert NB 0044 (see Declaration of Conformity).

Labeling:

Ex marking according 2014/34/EU				Ex marking according ISO 80079-36 / 80079-37			
CE	Ex	II	2G 2D	Ex h	IIC IIIC	T4 T95°C	Gb Db
CE	Conformity mark						
Ex	Explosion protection mark						
II	Group II equipment is intended for use in locations with explosive gas atmospheres, excluding mine gas and/or dust from hazardous mining operations.						
2G	Equipment group for gases and vapors in which an explosive atmosphere may occasionally occur during normal operation.						
2D	Equipment group for dusts in which an explosive atmosphere may occur during normal operation or for a short period.						
Ex h	Marking according to the equipment protection level for non-electrical equipment in potentially explosive atmospheres						
IIC	Suitable for gas atmosphere IIC						
IIIC	Suitable for combustible suspended solids, non-conductive and conductive dust						
T6...T1 T85°C...T450°C	Maximum surface temperatures which are mainly dependent on the operating conditions						
Gb	Equipment protection level for gases containing all potential ignition sources that are effective, which may occur during normal operation, rare and expected malfunctions.						
Db	Equipment protection level for dusts containing all potential ignition sources that are effective, which may occur during normal operation, rare and expected malfunctions.						

Recommended isolating switch amplifier		ATEX	SILx	Namur
Switch contact Code lxxxx	KCD2-SOT-Ex1.LB (1-channel) KCD2-SOT-Ex2 (2-channel)	x	SIL2	Namur
Switch contact Code lxxxxSN	KFD2-SH-EX1 (1-channel)	x	SIL3	Namur with safety function

4 Technical data

The detailed technical information can be found in the documents in the Appendix, Chapter 12.

5 Marking of the device

The nameplate with serial number and type designation is located on the housing. The materials used for the wetted parts as well as other device-specific versions are represented by a type coding on the nameplate and can be broken down at any time with the aid of the data sheet. The marking for the hazardous areas, in the form of the description of the type of protection, the permissible ambient temperature and the deposit number, are located in the lower area of the nameplate. If the differential pressure gauge is specified with an integrated inductive proximity switch the electrical parameters are mentioned on the name plate.

<p>Device without switching contacts: ###P5500 / P6500 ####ATEX</p>	<div style="border: 1px solid black; padding: 5px;"> <p>Article-no. Measuring range p max. Prod.-no.</p> <p style="text-align: right;">Ashcroft Instruments GmbH D - 52477 Alsdorf</p> <p style="text-align: center;"><i>Made in Germany</i></p> </div> <div style="border: 1px solid black; padding: 5px; margin-top: 5px;"> <p>CE Ex II 2G Ex h IIC T4 Gb II 2D Ex h IIIC T95°C Db</p> <p style="text-align: right;">Ashcroft Instruments GmbH D - 52477 Alsdorf</p> <p><small>Ta = -20°C to +60°C T medium in the device max. 85°C CE: File-No.: 8000395287 0044 TÜV NORD 2014/34/EU</small></p> </div>
<p>Device with integrated inductive proximity switch: ### P5500 / P6500 #### I####ATEX</p>	<div style="border: 1px solid black; padding: 5px;"> <p>Inductiv contact Zero position</p>  <p>Article-no. Contact function Measuring range p max. Prod.-no.</p> <p style="text-align: right;">Ashcroft Instruments GmbH D - 52477 Alsdorf</p> <p style="text-align: center;"><i>Made in Germany</i></p> </div> <div style="border: 1px solid black; padding: 5px; margin-top: 5px;"> <p>Connect to certified intrinsically safe electric circuits only!</p> <p>CE Ex II 2G Ex h IIC T4 Gb II 2D Ex h IIIC T95°C Db</p> <p style="text-align: right;">Ashcroft Instruments GmbH D - 52477 Alsdorf</p> <p><small>max. voltage: $U_{max} = 16\text{ V}$ max. current: $I_{max} = 25\text{ mA}$ max. output: $P_{max} = 64\text{ mW}$ max. capacity: $C_{max} = 30\text{ nF}$ max. inductance: $L_{max} = 100\text{ }\mu\text{H}$</small></p> <p><small>Ta = -20°C to +60°C T medium in the device max. 85°C CE: File-No.: 8000395287 0044 TÜV NORD 2014/34/EU</small></p> </div> <div style="border: 1px solid black; padding: 5px; margin-top: 5px;"> <p>Integrated inductive switches SJ 2-N</p> <p>PTB 99 ATEX 2219 X Ex II 2G Ex ia IIC T6...T1 Gb Ex II 1D Ex ia IIIC T200 135°C Da</p> <p style="text-align: right;">Ashcroft Instruments GmbH D - 52477 Alsdorf</p> </div>

6 Construction and function

6.1 Overview

1. Diaphragm
2. Rod
3. Movement

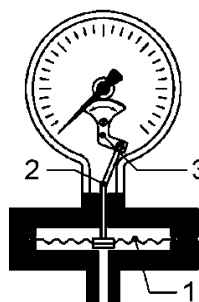

6.2 Description of function

The sensing element, the concentrically rippled diaphragm element, is clamped in place between two flanges and charged with the medium on one side.

Under the pressure acting on it, there is an elastic displacement out of the normal position. This displacement is proportional to the adjacent pressure. On the side of the diaphragm element facing away from the medium, a rod picks up the displacement and transfers it to a movement mechanism.

The display of the measured value is given on a 270° scale.

6.1 Description of components

6.1.1 Scale with pointer

The pressure gauge is equipped with a dial face and pointer pursuant to EN 837-3, nominal size 100 mm or 160 mm.

6.1.2 Instrument connection

The instrument connection is located on the underside of the pressure gauge and can be a threaded or flanged connector.

6.1.3 Vent and flushing connection

The vent valve for the housing is located on the top side. If the nipple is pulled out, the housing is ventilated and the pressure which has built up in the housing due to the influence of temperature is discharged. With the valve closed, protection class IP 65 is achieved.

6.1.4 Rear wall/plug with blow-out capability

The pressure gauge has a plug capable of blowing out on the rear wall of the housing (Model P5500) or a rear wall capable of blowing out (Model P6500). These act as a safety feature pursuant to EN 837-3 and simultaneously allow for temperature compensation for the housing, via a rubber membrane.

6.2 Accessories

Please contact the manufacturer regarding special tools and accessories.

7 Transport

7.1 Safety

The pressure gauge should be protected against the effects of knocks and impacts. The device should only be transported in the packaging provided, to protect against glass breakage. The device should only be transported in a clean condition (free of residues of measuring media).

7.2 Transport inspection

The delivery must be checked for completeness and damage during transport. In the event of damage during transport, the delivery must not be accepted, or only accepted subject to reservation of the scope of the damage being recorded and, if necessary, a complaint initiated.

7.3 Storage

The differential pressure gauge must be stored in dry, clean conditions, within a temperature range of -40 to +70 °C, protected against direct exposure to sunlight and protected against impact damage.

8 Assembly/Installation

8.1 Safety

To ensure safe working during installation and servicing, suitable shut-off valves must be installed in the plant (see 6.2 Accessories), enabling the device:

- To be depressurized or taken out of operation;
- To be disconnected from the mains supply for repair or checks within the relevant plant;
- Or to enable function tests of the device to be performed “on site”.

During the works to mount/install the gauge, the plant must be protected against being switched back on.

8.2 Preparations (requirements for the installation location)

- A check on suitability of the device for the medium to be measured, the scope of the measurement range and of the protection against special conditions such as vibrations, pulsations and pressure spikes.
- A bracket must be installed to support the pressure gauge if the metering pipe is not able to provide adequate support.
- Devices with a blow-out require a minimum spacing to the rear (20 mm).
- The installation location should be chosen such that the work-spaces for operating personnel are not located to the rear of the pressure gauge.

8.3 Mounting/Installation

8.3.1 Process connection

As standard, the device is equipped for pipework mounting with a pressure connection shank pursuant to DIN EN 837-3. The device is calibrated ex works for vertical installation.

- Connection to be undertaken by authorized and qualified specialist staff only.
- Use only with the mechanical process connection provided – regarding the configuration, see order code on the device type label, with a matching threaded seal.
- When connecting the device, the pipes must be depressurized.
- The pressure metering pipe must be laid inclined in such a way that, for example, for measurements of fluids no air pockets can form, and for measurements of gases no water pockets. If the necessary incline is not achieved, then at suitable points water separators or air separators must be installed.
- The pressure metering pipe must be kept as short as possible and laid without sharp bends, to avoid the occurrence of irritating delays.
- With liquid measurement media, the pressurized connection pipe must be degassed, since any gas bubble inclusions result in measurement error.
- If water is used as the measurement medium, the device must be frost-protected.



Safety notice: Only mount using the correct open-jawed wrench, and do not twist the device itself.

8.3.2 Electrical connection



Take note of the electrical data in the EU design type test certification and the locally-applicable regulations and guidelines for installing and operating electrical plant in explosion risk areas (e.g. EN 60079-14, EN 60079-17 etc.).

- Connection to be undertaken by authorized and qualified specialist staff only.
- The electrical connection of the device is to be undertaken in accordance with the relevant regulations of the VDE and the regulations supplied by the local utilities company.
- Disconnect the plant from the mains supply before wiring electrical connections.
- Install appropriate fuses upstream.
- Differential pressure gauges with ATEX approval are equipped with a grounding screw, the grounding must be proper connected.

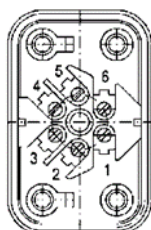

Please refer to type label for configuration of connections.



Grounding connector for single wire conductor
4 ... 6 mm²

8.4 Starting up

The precondition for start-up is proper installation of all electrical feed lines and metering pipes. All connecting lines must be laid such that no mechanical forces can act on the device.

Before start-up, the seal on the pressurized connection line must be checked.

8.4.1 Zero point adjustment

The pressure gauges are supplied calibrated ex works, so that as a rule there is no need for calibration works at the installation point.

On some devices (see order code), zero point adjustment on site is possible. For this, proceed as follows:

- Depressurize the pressure metering pipe.
- Open the vent valve as shown in the diagram, and carefully remove the entire valve bushing from the housing.
- Adjust the indicator arm using the zero point adjustment screw to the zero point on the scale.
- Refit the valve bushing in the housing.
- Close the vent valve.

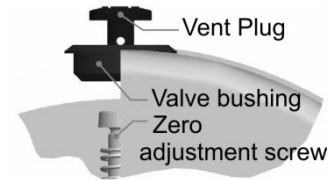

8.4.2 Setting the switch point

An adjustable lock is fitted in the front panel of the pressure gauge. Using the removable adjustment key, the contacts mounted on the target value indicators can be set to any point on the range covered by the scale.

For reasons relating to accuracy of switching and the lifetime of mechanical measurement systems, the switch points should be positioned between 10% and 90% of the range.

- Place the adjustment key on the axle of the adjustable lock.
- Press the axle inwards, until the carrier arm grips behind the adjuster pin on the target value indicator.
- By turning the key, adjust the target value indicator to the desired switch point.

Release the pressure on the axle, and remove the adjustment key.

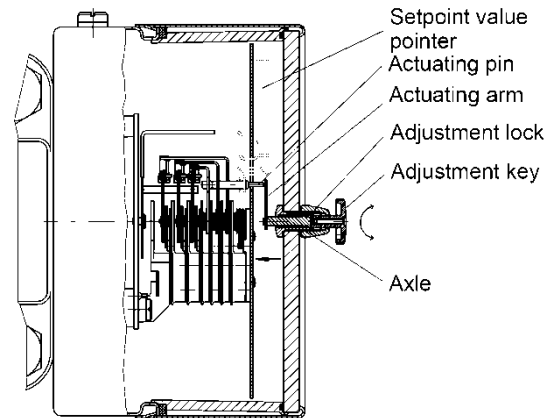

8.4.3 Contact function

Function 1: Close contacts with the indication rising in a clockwise direction.

Function 2: Open contacts with the indication rising in a clockwise direction.

Contact assignment:

- 1st contact left target value indicator,
- 2nd contact middle target value indicator,
- 3rd contact right target value indicator

8.5 Subsequent relocation of the gauge (by the customer)



Recommendation: Do not remove the differential pressure gauge from one metering point and fit it in a different place, as there is a risk of the measuring media being mixed, with unforeseeable chemical reactions.

9 Servicing

The device is maintenance-free. However, to ensure reliable operation and a long lifetime for the device, we recommend that it is checked regularly.

9.1 Safety

When undertaking servicing work on the device, the pressure lines must be depressurized, the electrical connections isolated from the mains supply, and the plant secured against being switched on again.

9.2 Check on function, and recalibration

The check on function and recalibration is carried out at regular intervals, depending on the application. The precise testing cycles should be adjusted in line with the operating conditions and ambient conditions. In the event of various device components interacting, the operating instructions for all other devices should also be taken into account.

- Check on display.
- Check on function, in conjunction with downstream components.
- Check of pressurized connection pipes for seal condition.
- Check of electrical connections.

9.3 Cleaning and maintenance

Cleaning is carried out using a non-aggressive cleaning agent, with the ventilation valve closed and respecting the protection category of the device.

10 Faults

10.1 Safety

Defective or faulty pressure gauges put the operational safety and process safety of the plant at risk, and can lead to a risk or injury to persons, the environment or the plant.

10.2 Conduct in the event of faults

All defective or faulty devices must be taken out of service. If a repair is required, the device must be sent directly to our Repairs Department. We request that all returns of devices are agreed with our Service Department.

10.3 Fault table

Possible situations indicating a fault:

- Jerky or random movement of the pointer
- Pointer does not set to zero for pressure less display
- Bent or loose pointer
- Cracked window
- Leaks when the device is filled
- Damage to housing
- Indications that the measurement system seal is imperfect (discoloration to dial display or of filling liquid)

In these instances, replacement of the pressure gauge is always required.

10.4 Conduct following fault rectification

See Chapter 8.3 Mounting/Installation

11 Removal, disposal

11.1 Safety



Residues of measuring media in and on removed gauges can constitute a risk to people, the environment and equipment. Adequate precautionary measures must be adopted. If necessary, the devices must be cleaned thoroughly (see advice in safety data sheets).

11.2 Removal

- When undertaking servicing work on the device, the pressure lines must be depressurized, the electrical connections isolated from the mains supply, and the plant secured against being switched on again.
- Demount the gauge using a suitable tool

11.3 Disposal



At the end of the product life cycle, do not dispose of this product with normal household waste. Take this product to a collection point or a specialist disposal company for recycling of the components.

With the help of the product coding and our data sheets (see Appendix 12.1 available on our website) you will receive the necessary information to be able to carry out a material separation yourself. Our devices described in this manual are mostly made of stainless steels which can be recycled. Before disassembling, check if there is a device filled with filling fluid. This fluid must first be drained off and collected in accordance with the safety instructions in the safety data sheet. Then separate the case ring, which carries the window, from the case using a strap wrench. The sealing ring and flat glass can be removed. Next, remove the pointer and dial, which are made of aluminum. Dismantle the venting and pressure equalization device last, everything else is made of stainless steel.

Materials to be recycled:

- Filling fluid (oil see data sheet)
- Stainless steel (case, case ring, pressure chambers, movement see data sheet)
- Dial and pointer (aluminum)
- Window (see data sheet)

Seals (sealing ring of the sight glass, venting device, pressure relief device)

Please help to protect our environment!



Some of the product materials can be reused if you take the product to a collection point or to a waste management company. By reusing some parts or raw materials from used products, you make an important contribution to protecting the environment.

Our products are delivered in optimized packaging. This essentially means that materials are used which can be recycled as secondary raw materials at the local disposal service. For more information on the disposal of packaging, please contact your local administration.

12 Appendix







12.1 Data Sheet Differential Pressure Gauge P5500 / P6500

Detailed data sheet is available from supplier's website (see 1.6 Manufacturer's address, customer services)





This Table refers to specific documents:

Model	Description	Document
P5500	Diaphragm type pressure gauge model P5500	G1.P5500
P6500	Solid front diaphragm type pressure gauge model P6500	G1.P5500
K5500	Electrical contact devices for pressure and temperature gauges	G1.K5500

12.2 EU Declaration of conformity model P5500 and P6500

 ASHCROFT® Trust the shield.®	EU-Konformitätserklärung EU-Declaration of Conformity EN ISO / IEC 17050-1:2010
Ashcroft Instruments GmbH Max-Planck-Straße 1-9 52477 Aisdorf	
erklärt in alleiniger Verantwortung, dass die mit CE gekennzeichneten Produkte <i>declares in sole responsibility that the products marked with CE</i>	
Gerät: <i>Equipment:</i>	Plattenfederanometer vom Typ P5500 / P6500 mit Membran als elastisches Messglied Diaphragm type pressure gauge Type P5500 / P6500 with diaphragm as an elastic measuring element
Kennzeichnung: <i>Marking:</i>	TÜV 8000395287   II 2G Ex h IIC T4 Gb II 2D Ex h IIIC T95°C Db Ta = -20°C to +60°C
Herstellungsdatum: <i>Date of manufacture:</i>	ab 01.12.2024 from 1 st of December 2024
die grundlegenden Sicherheits- und Schutzanforderungen erfüllen, in Übereinstimmung mit den unten genannten Richtlinien und Normen. Die Konformitätsaussage bezieht sich auf die Konzeption und Fertigung der oben genannten Produkte. <i>the fundamental safety and protection requirements passed in accordance with the guidelines and standards listed below. This declaration of conformity refers to the design and manufacture of the above products.</i>	
Richtlinie <i>Directive</i>	2014/34/EU „Geräte und Schutzsysteme zur bestimmungsgemäßen Verwendung in explosionsgefährdeten Bereichen“ <i>“equipment and protective systems intended for use in potentially explosive atmospheres”</i>
Harmonisierte Normen <i>Harmonized Standards</i>	EN ISO 80079-36:2016, EN ISO 80079-37:2016, EN 60079-0:2018, EN 60079-31:2014
Benannte Stelle 0044 <i>Notification Body</i>	TÜV NORD CERT Am TÜV 1 30519 Hannover, Germany
Hinterlegungsnummer: <i>Dossier File No.:</i>	8000395287
Druckgeräte Richtlinie <i>PED Directive</i>	⁽¹⁾ 2014/68/EU „Druckgeräterichtlinie“ <i>“Pressure Equipment Directive”</i>
Angewendete Prüfnormen: <i>Used test standards:</i>	EN 837-1,2,3:1996
⁽¹⁾ PS >200 bar und V <0,1l, gemäß Anhang II, Art.4, Diagr.1, „Drucktragende Ausrüstungsteile“, Modul A. <i>PS >200 bar and V <0.1l, according to Annex II, Art.4, Diagr.1, “Pressure Accessories”, Module A.</i>	
Richtlinie <i>Directive</i>	2011/65/EU „Richtlinie zur Beschränkung der Verwendung bestimmter gefährlicher Stoffe in Elektro- und Elektronikgeräten“ <i>“Directive on the restriction of the use of certain hazardous substances in electrical and electronic equipment”</i> 2015/863/EU „Änderung von Anhang II der Richtlinie 2011/65/EU“ <i>“Amending Annex II to Directive 2011/65/EU”</i>
Bewertung <i>Evaluation</i>	Die oben aufgeführten Produkte fallen nicht unter diese Richtlinie, da es sich nicht um elektrische oder elektronische Geräte handelt. <i>The products listed above are not covered by this directive as they are not electrical or electronic equipment.</i>
Aisdorf, den 05.11.2024 Ort und Datum <i>Place and date</i>	 ATEX Verantwortlicher <i>ATEX Manager</i>
Digitale Ausführungen nur mit validierter Unterschrift gültig. Die gültige Validierung ist in einem unveränderten Dokument enthalten. <i>Digital executions valid only with validated signature. The valid validation is included in an unmodified document.</i>	
Ashcroft Instruments GmbH www.ashcroft.eu	Fon: +49 (0) 2404 / 5589-888  

12.3 EU Declaration of conformity model P5500 and P6500 with contacts

 ASHCROFT® Trust the shield.®		EU-Konformitätserklärung EU-Declaration of Conformity EN ISO / IEC 17050-1:2010	
Ashcroft Instruments GmbH Max-Planck-Straße 1-9 52477 Alsdorf			
erklärt in alleiniger Verantwortung, dass die mit CE gekennzeichneten Produkte <i>declares in sole responsibility that the products marked with CE</i>			
Gerät: Equipment:	Plattenfedermanometer vom Typ P5500 / P6500 mit induktivem Näherungsschalter Diaphragm type pressure gauge Type P5500 / P6500 with inductive proximity switch		
Kennzeichnung: Marking:	TÜV 8000395287   II 2G Ex h IIC T4 Gb II 2D Ex h IIC T95°C Db Ta = -20°C to +60°C		
Herstellungsdatum: Date of manufacture:	ab 01.12.2024 from 1 st of December 2024		
die grundlegenden Sicherheits- und Schutzanforderungen erfüllen, in Übereinstimmung mit den unten genannten Richtlinien und Normen. Die Konformitätsaussage bezieht sich auf die Konzeption und Fertigung der oben genannten Produkte. <i>the fundamental safety and protection requirements passed in accordance with the guidelines and standards listed below. This declaration of conformity refers to the design and manufacture of the above products.</i>			
Richtlinie Directive	2014/34/EU „Geräte und Schutzsysteme zur bestimmungsgemäßen Verwendung in explosionsgefährdeten Bereichen“ <i>“equipment and protective systems intended for use in potentially explosive atmospheres”</i>		
Harmonisierte Normen Harmonized Standards	EN ISO 80079-36:2016, EN ISO 80079-37:2016, EN 60079-0:2018, EN 60079-31:2014		
Benannte Stelle 0044 Notification Body	TÜV NORD CERT Am TÜV 1 30519 Hannover, Germany		
Hinterlegungsnummer: Dossier File No.:	8000395287		
EG- Baumusterprüfbescheinigung EC-Type-Certified	Induktive Näherungsschalter <i>inductive proximity switch</i>	PTB 99 ATEX 2219X	
Druckgeräte Richtlinie PED Directive	(1)2014/68/EU „Druckgeräterichtlinie“ <i>“Pressure Equipment Directive”</i>		
Angewendete Prüfnormen: Used test standards:	EN 837-1,2,3:1996		
(1) PS >200 bar und V <0,1l, gemäß Anhang II, Art.4, Diagr.1, „Drucktragende Ausrüstungsteile“, Modul A. <i>PS >200 bar and V <0.1l, according to Annex II, Art.4, Diagr.1, “Pressure Accessories”, Module A.</i>			
Richtlinie Directive	2011/65/EU „Richtlinie zur Beschränkung der Verwendung bestimmter gefährlicher Stoffe in Elektro- und Elektronikgeräten“ <i>“Directive on the restriction of the use of certain hazardous substances in electrical and electronic equipment”</i> 2015/863/EU „Änderung von Anhang II der Richtlinie 2011/65/EU“ <i>“Amending Annex II to Directive 2011/65/EU”</i>		
Bewertung Evaluation	Das oben benannte Produkt erfüllt die Anforderungen der derzeit gültigen EU Richtlinien. <i>The above-mentioned product comply with the currently valid provisions of EU Directive.</i>		
Alsdorf, den 05.11.2024 Ort und Datum <i>Place and date</i>		  ATEX Verantwortlicher ATEX Manager	
Digitale Ausführungen nur mit validierter Unterschrift gültig. Die gültige Validierung ist in einem unveränderten Dokument enthalten. Digital executions valid only with validated signature. The valid validation is included in an unmodified document.			
Ashcroft Instruments GmbH Fon: +49 (0) 2404 / 5589-888 www.ashcroft.eu		