

Installation and Maintenance Instruction Manual

Pressure limiting valve

for industrial application in the following configuration:

- ###PL02### Pressure Limiting Valve model PL02



Table of contents:

1	General remarks.....	3
1.1	Purpose of this Manual.....	3
1.2	Symbols.....	3
1.3	Limits of liability.....	3
1.4	Copyright.....	3
1.5	Warranty.....	3
1.6	Manufacturer's address, customer services.....	3
2	Safety.....	3
2.1	General sources of hazards.....	3
2.2	Use in accordance with intended purpose.....	3
2.3	Operator's responsibility.....	3
2.4	Staff qualifications (target group assessment).....	4
2.5	Signs/Safety markings.....	4
2.6	Environmental protection.....	4
3	Technical data.....	4
4	Labeling on the device.....	4
5	Construction and function.....	5
5.1	Description of function.....	5
5.2	Material Suitability.....	5
5.3	Information on the pressure equipment.....	5
5.4	Accessories.....	5
6	Transport and storage.....	5
7	Assembly/Installation.....	6
7.1	Safety.....	6
7.2	Preparations (requirements for the installation location).....	6
7.3	Mounting/Installation.....	6
8	Servicing.....	7
8.1	Resealing of the packing (not for O-Ring Type).....	7
8.2	Maintenance and repair.....	7
8.3	Replacing the valve head unit / valve seat.....	7
8.4	Safety.....	7
8.5	Check on function.....	7
8.6	Cleaning and maintenance.....	7
9	Faults.....	7
9.1	Safety.....	7
9.2	Conduct in the event of faults.....	7
9.3	Fault table.....	8
10	Removal, disposal.....	8
10.1	Safety.....	8
10.2	Removal.....	8
10.3	Disposal.....	8
11	Appendix.....	8
11.1	Data sheets for Valves and Manifolds.....	8

1 General remarks

1.1 Purpose of this Manual

This Operating Manual contains fundamental and essential advice to be followed for the installation, operation and servicing of the device. It must be read without fail before assembly and start-up of the device by the fitter, the operator and the specialist personnel responsible for the device. This Operating Manual must be available at the point of use at all times.

The following sections about general safety information (2) and also the following specific advice regarding the intended purposes (2.2) and through to disposal (10.3) contain important safety information which, if not followed, may result in risks for people and animals, or to property and buildings.

1.2 Symbols



Warning!

This indicates a possibly hazardous situation where failing to follow advice may result in risks to people, animals, the environment and buildings.



Information!

This emphasizes key information for efficient, fault-free operation.

1.3 Limits of liability

Failure to respect this safety information, the envisaged uses or the limit values relating to use indicated in the technical data for the device may result in risk or to injury to people, the environment or the plant.

Claims for compensation for damage against the device supplier are excluded in such an eventuality.

1.4 Copyright

This Operating Manual may only be copied and passed on as a complete document without the special permission of the publisher.

1.5 Warranty

For the product described here, we offer a warranty pursuant to Section 6 Guarantee in Respect of Defects in our General Terms and Conditions of Delivery and Payment.

1.6 Manufacturer's address, customer services

Ashcroft Instruments GmbH
Max-Planck-Strasse 1
D-52499 Baesweiler. Germany

Tel.: +49 (0) 2401/808-888
Fax.: +49 (0) 2401/808-999
E-mail: customer.service@ashcroft.com
Web: www.ashcroft.eu

2 Safety

2.1 General sources of hazards

Manifolds are pressurized parts where failure can result in hazardous situations.

2.2 Use in accordance with intended purpose

The devices are only to be used for the intended purpose as described by the manufacturer.

For each use scenario, the corresponding set-up regulations must be respected.

2.3 Operator's responsibility



The adjustable gauge protector serves as a protection against excess pressures exceeding the measurement range of the manometers used. Installation and maintenance work must only be performed by qualified staff.

In addition to these operating instructions are also the general safety and accident prevention regulations as well as the operating instructions of the plant and the measuring device used to Note.

The permissible operating conditions should be taken in accordance with the valve drawing. The respective pressure / temperature diagrams represent the permissible operating conditions.

2.4 Staff qualifications (target group assessment)

The device may only be installed and started up by specialist staff who are familiar with installation, start-up and operation of the product.

Specialist staff are people who are able to assess the work assigned to them on the basis of their specialist training, their knowledge and experience and their knowledge of the relevant standards, and can identify possible risks.

2.5 Signs/Safety markings

The manifolds and its surrounding packaging carry markings. These markings show the article number, pressure rating and manufacturer. The manifold can be provided with additional signs and safety markings advising on special conditions:

- Oil-can deleted (if oxygen is used)



Pressure limiting valves for manometers are used with various media. They can be poisonous, irritating or very hot. Any assembly and maintenance work must only be carried out by experienced and trained personnel. The generally valid regulations on health and safety as well as accident prevention must be observed in addition to this operating manual and the operating instructions for the system and manometers that are used.

2.6 Environmental protection

This device does not contain any environmental critical component.

3 Technical data

The maximum permitted inlet pressure is 600 bar for the brass type and 1000 bar for the stainless steel type. Oil/grease-free type gauge protectors for oxygen operation (option X=6B) have a maximally permitted 250 bar operating pressure.

The maximum operating temperature is 80°C. (or 60°C for option X=6B).

Use beyond these limits and any unauthorised modifications are not permitted and relieve the manufacturer from liability for any consequential damage that may arise.

The detailed technical information can be found in the documents in the Appendix, Chapter 11.

4 Labeling on the device

The label with the serial number, direction arrow, set point, pressure rating class and type designation is located on the valve body. The materials identifier is encoded in the type designation.

5 Construction and function

5.1 Description of function

When the set pressure is reached, the valve automatically closes, thus blocking off the flow to the pressure instrument. When the pressure falls approx. 25% under the closing pressure, the valve opens and again releases the flow.

The gauge protectors have the following set ranges:

0.4 – 2.5 bar, 2 – 6 bar, 5 – 25 bar, 20 – 60 bar, 50 – 250 bar, 240 – 400 bar and 400 – 600 bar

The 400 - 600 bar set range is not available for the DVGW type.

The oil/grease-free type for oxygen operation has the following set ranges:

0.4 – 2.5 bar, 2 – 6 bar, 5 – 25 bar, 20 – 60 bar and 50 – 250 bar

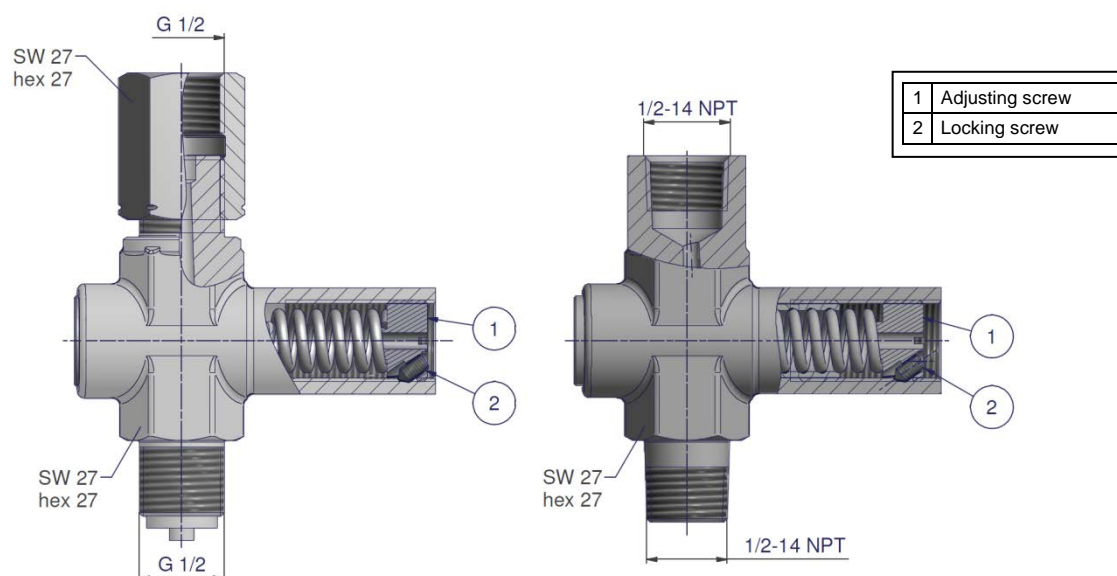

5.2 Material Suitability

In particular, it must be ensured that the selected materials for the wetted parts of the shut-off valve for the media being used are appropriate. The manufacturer is not responsible for damage caused by corrosive media on the shut-off valve.

Failure to observe this precaution can mean danger for the user and the damage to the pipe system.

5.3 Information on the pressure equipment

The permissible operating pressure depends on the temperature of the medium and of the materials used and seals. This can be found in the corresponding catalogue sheets or drawings.

5.4 Accessories

Please contact the manufacturer regarding special tools and accessories.

6 Transport and storage

The valve may be used only in original packed status stored to avoid soiling or damage. The transport of the valve may only be carried out in a pressure-free condition.

7 Assembly/Installation

7.1 Safety

The gauge protector must be connected via the inlets and outlets provided. Additional introduction of forces, bending strains applied to the female connectors via piping connections must be strictly avoided. Weld seams on connections must be welded and tested in compliance with valid and approved welding methods. If the weld ends are made of steel, they must be painted after welding in order to avoid corrosion.

- To be depressurized or taken out of operation;
- To be disconnected from the mains supply for repair or checks within the relevant plant;

During the works to mount/install the limiting valve, the plant must be protected against being switched back on.

7.2 Preparations (requirements for the installation location)

- A check on suitability of the device for the medium, pressure and temperature range

7.3 Mounting/Installation

7.3.1 Installation conditions

The following installation conditions apply to the industrial valves:

Industrial valves must be installed so that employees or third parties are not compromised.

The required safety distances for installation in accordance with the applicable national legal provisions shall be complied with.

The industrial valves must be so positioned or installed, that

- they are accessible for any necessary inspection and are clearly visible,
- the labelling is clearly legible,
- Operation of the industrial valve is possible from a safe distance.
- Connection to be undertaken by authorized and qualified specialist staff only
- Use only with the mechanical process connection provided – regarding the configuration, see order code on the device type label, with a matching threaded seal.
- When connecting the device, the pipes must be depressurized.

The valve must be protected against mechanical impact from outside as far as protected so that damage to the valve is not expected to occur.

The industrial valve must be protected from tampering by unauthorized staff.

The factory setting for the gauge protectors is the mean figure of the respective pressure range. If requested, the gauge protectors can be pre-set to a different pressure.

If appropriate measurement equipment is available, the adjusting screw (1) can be used to set the gauge protector within the respective pressure range.

To do this, proceed as follows:

- Slacken the locking screw (2).
- Set the required pressure using the adjusting screw (1). (pressure increase by turning clockwise)

Re-tighten the locking screw (2).



Safety notice: Only mount using the correct open-jawed wrench, and do not twist the device itself.

7.3.2 Operation

Refer to the gauge protector drawing for the permissible operating conditions.

8 Servicing

8.1 Resealing of the packing (not for O-Ring Type)

The factory setting for the packing (4; spindle seal to the outside) is 1.5 times the nominal pressure on the test stand. Due to long-term storage, the packing that is not under pressure may lose its leak tightness. In this case, it must be readjusted.

Readjustment is as follows:

Open the stem (2), release the hexagon nut (7) and retighten the gland nut (6). Usually, 1/4 to 1/2 a rotation is enough. If that is not enough, repeat the procedure. After this, secure the hexagon nut (7) again and check that the stem moves easily.

Necessary tools: A/F 16, A/F 19 and A/F 22 flat wrench.

If resealing is not successful, you must replace the valve head unit.

8.2 Maintenance and repair

You must check the gauge protectors regularly for tightness and damage.



Worn or damaged gauge protectors cannot be repaired by the customer. They must be returned to the manufacturer for exchange or repair. They must only be disassembled when depressurised! Even when depressurised, the components can stay very hot for a long time! Small amounts of medium may escape during disassembly! Protective goggles and gloves must be worn!

8.3 Replacing the valve head unit / valve seat

Necessary tools: A/F2.5 hex. socket wrench, A/F19 socket wrench, Combination pliers, A/F16 and A/F22 torque wrench; hammer, punch.

8.4 Safety

When undertaking servicing work on the device, the pressure lines must be depressurized, and the plant secured against being switched on again.

8.5 Check on function

The check on function is carried out at regular intervals, depending on the application. The precise testing cycles should be adjusted in line with the operating conditions and ambient conditions. In the event of various device components interacting, the operating instructions for all other devices should also be taken into account.

- Check on function, in conjunction with downstream components.
- Check of pressurized connection pipes for seal condition.

8.6 Cleaning and maintenance

Cleaning is carried out using a non-aggressive cleaning agent, with the ventilation valve closed and respecting the protection category of the device.

9 Faults

9.1 Safety

Defective or faulty manifolds put the operational safety and process safety of the plant at risk, and can lead to a risk or injury to persons, the environment or the plant.

9.2 Conduct in the event of faults

All defective or faulty devices must be taken out of service. If a repair is required, the device must be sent directly to our Repairs Department. We request that all returns of devices are agreed with our Service Department.

9.3 Fault table

Possible situations indicating a fault:

- Leaks
- Damage to valve body

In these instances, replacement of the manifold is always required.

10 Removal, disposal

10.1 Safety



Residues of measuring media in and on removed measuring devices can constitute a risk to people, the environment and equipment. Adequate precautionary measures must be adopted. If necessary, the devices must be cleaned thoroughly (see advice in safety data sheets).

10.2 Removal

- When undertaking servicing work on the device, the pressure lines must be depressurized and the plant secured against being switched on again.
- Demount the manifold using a suitable tool

10.3 Disposal



Please help to protect the environment and dispose of or recycle the devices and components used in accordance with the applicable regulations.

11 Appendix

11.1 Data sheets for Valves and Manifolds

Detailed data sheet is available from supplier's website (see 1.6 Manufacturer's address, customer services)

This Table refers to specific documents:

Model	Description	Document
PLV	Pressure limiting valve	DS PLV EN