

F5503 Differential Pressure Gauge

FEATURES

- Robust stainless steel housing
- Dry or liquid filled
- Available with diaphragm seals
- Electric contacts (optional)
- Flow measurement dial (optional)
- Ranges from 0 ... 25 mbar to 0 ... 40 bar

TYPICAL USES

- Refineries
- Power plants
- Chemical and petrochemical plants
- Water and wastewater pressure control
- Marine and Offshore
- Mining and metals
- Filtration monitoring, level and flow measurement



F5503
100 mm dial size



SPECIFICATIONS

Accuracy:	± 1,6 % of span optional: ± 1,0 % or ± 0,5 % acc. to ASME B40.100 upscale				
Dial Size:	100 mm or 160 mm				
Zero Adjustment:	External				
Range:	0 ... 25 mbar to 0 ... 40 bar, see table at page 5				
Static Pressure:	100 bar or optional up to 400 bar				
Process Connection Location:	Lower and Top				
Fill Fluid:	Dry, Glycerine, Silicone, Halocarbon®, Korasilon® (Electrical contacts)				
Process Connection Size:	Flange connection acc. DIN 61518 with G ½ female or ½ NPT female; Welding port diameter 8 mm				
	Adapters:	<table border="1"> <thead> <tr> <th>Male</th> <th>Female</th> </tr> </thead> <tbody> <tr> <td>G ¼ B or G ½ B ¼ NPT or ½ NPT M20x1,5</td> <td>G ¼ ¼ NPT</td> </tr> </tbody> </table>	Male	Female	G ¼ B or G ½ B ¼ NPT or ½ NPT M20x1,5
Male	Female				
G ¼ B or G ½ B ¼ NPT or ½ NPT M20x1,5	G ¼ ¼ NPT				
Window Material:	Laminated Safety Glass (standard) Polycarbonate (optional)				
Dial:	Aluminum, black markings on white background				
Pointer:	Aluminum, black Red set hand or maximum pointer (optional)				
Weather Protection:	Dry: IP65 Liquid filled and LJ: IP66 and NEMA 4X (optional)				
Mounting:	Wall-, Pipe- or Panel mounting				
Approval:	CE, CRN, EAC, CPA ATEX File No. 35106158 at notified body 0044				

WETTED COMPONENTS

Pressure chamber	Process Connection	Measuring Diaphragm	
St. st. 316L (1.4404)	St. st. 316L (1.4404)	≤ 400 mbar ≥ 0,6 bar 40 bar	St. st. 316Ti (1.4571) DURATHERM® Inconel® 718 (2.4668)
Hastelloy® C-276	Hastelloy® C-276	≤ 2,5 bar ≥ 4 bar	Hastelloy® C-276 St. st. 316Ti with Hastelloy® C-276 foil
St. st. 316L (1.4404)	St. st. 316L (1.4404)	≥ 0,6 bar	Monel® 400 (2.4360)

KEY BENEFITS

- High static pressure with low differential pressure
- Perfect solution for challenging applications and installation requirements
- Robust design with dual diaphragms for safety
- NACE compliant
- Designed for harsh services



NON-WETTED COMPONENTS

Case	Ring	O-Ring
St. st. 304 (1.4301) opt.: St. st. 316L (1.4404)	St. st. 304 (1.4301) opt.: St. st. 316L (1.4404)	Viton® (FKM)

MIN./MAX. TEMPERATURE LIMITS

VERSION	AMBIENT	PROCESS	STORAGE
Dry	-20 °C to 80 °C (-4 °F to 176 °F)	-20 °C to 100 °C (-4 °F to 212 °F)	-40 °C to 80 °C (-40 °F to 176 °F)
Glycerine	-7 °C to 80 °C (19 °F to 176 °F)	-7 °C to 80 °C (19 °F to 176 °F)	-7 °C to 80 °C (19 °F to 176 °F)
Silicone	-20 °C to 80 °C (-4 °F to 176 °F)	-20 °C to 100 °C (-4 °F to 212 °F)	-40 °C to 80 °C (-40 °F to 176 °F)
Halocarbon®	-20 °C to 80 °C (-4 °F to 176 °F)	-20 °C to 100 °C (-4 °F to 212 °F)	-40 °C to 80 °C (-40 °F to 176 °F)
ATEX	-20 °C to 60 °C (-4 °F to 140 °F)	-20 °C to 60 °C (-4 °F to 140 °F)	-20 °C to 60 °C (-4 °F to 140 °F)
Korasilon®	-20 °C to 80 °C (-4 °F to 176 °F)	-20 °C to 100 °C (-4 °F to 212 °F)	-20 °C to 80 °C (-4 °F to 176 °F)
Low Temperature	-40 °C to 80 °C (-40 °F to 176 °F)	-40 °C to 100 °C (-40 °F to 212 °F)	-40 °C to 80 °C (-40 °F to 176 °F)

Note: Accuracy at temperatures above or below the reference ambient temperature of 20 °C (68 °F) will be affected by approximately 0,3% per 10 K.



 II 2G Ex h IIC T4 Gb
 II 2D Ex h IIIC T95°C Db
 Ta = -20 °C to +60 °C

F5503 Differential Pressure Gauge

ORDERING CODE		EXAMPLE:	100	F5503	S	-	51	L	1BR	XC3
Dial Size										
100	100 mm		100							
160	160 mm									
Model Code				F5503						
F5503	Differential Pressure Gauge, Safety design, Cylindrical case Static pressure max. 100 bar			F5503						
F5503HP	Differential Pressure Gauge, Safety design, Cylindrical case High Static pressure up to 400 bar									
Pressure Chamber and Measuring Diaphragm (depending on pressure ranges, see table at page 5)										
S	Stainless steel 316L (1.4404) Pressure Chamber with Stainless steel 316Ti (1.4571), DURATHERM® or Inconel® 718 (2.4668) measuring diaphragm				S					
SH	Stainless steel 316L (1.4404) Pressure Chamber with Hastelloy® C-276 measuring diaphragm									
HH	Hastelloy® C-276 Pressure Chamber with Hastelloy® C-276 measuring diaphragm									
SM	Stainless steel 316L (1.4404) Pressure Chamber with Monel® 400 (2.4360) measuring diaphragm (Only for PN100 and ranges ≥ 600 mbar)									
Case Filling										
	Dry case (standard)					-				
L	Liquid filled case (glycerine is standard if no other filling fluid is indicated)									
Process Connection										
02	¼ NPT Male									
04	½ NPT Male									
13	G 1/4 B Male									
15	G 1/2 B Male									
16	M20x1,5 Male									
25	1/4 NPT Female									
27	G 1/4 Female									
50	1/2 NPT Female and oval flange for direct mounted manifold									
51	G 1/2 Female and oval flange for direct mounted manifold						51			
00T	Welding port Ø 8 mm									
Process Connection Location										
L	Lower							L		
T	Top (12 o'clock position)									
Range (coding example only, see range table on page 5 for all standard ranges)										
Single Scales										
1BR	1 bar								1BR	
Options (If choosing an option(s) must include a "X")										X_
Accuracy (not available for electrical contacts)										
AJ	0,5 % Accuracy, ascending (Only available in ranges > 250 mbar and ≤ 25 bar, not available for Hastelloy® C-276 with range ≥ 4 bar)									
AN	1,0 % Accuracy (With Hastelloy® C-276 diaphragm only available for ranges ≥ 4 bar)									
Agency Approval										
A8	CRN (Canadian Registration Number)									
ATEX	ATEX approval Ex II 2 GD									
EAC	Certificate of conformance according EAC (not available for ATEX execution)									
Case Material										
PT	O-ring between body and chamber (only PN100; PTFE for ranges ≤ 2,5 bar; FFKM for ranges > 2,5 bar)									
TB1	Purge and vent connection ¼ NPT Female									
YW	Stainless steel 316L (1.4404) housing (not available for electrical contacts)									



F5503 Differential Pressure Gauge

ORDERING CODE	EXAMPLE:	100	F5503	S	-	51	L	1BR	XC3
----------------------	-----------------	-----	-------	---	---	----	---	-----	-----

Options (If choosing an option(s) must include a "X")

X_

Case/Ring/Dial

FF	Front flange, panel mounting
FF1	Front flange with support bracket for weight relief, panel mounting (only available for ranges ≥ 600 mbar)
FW	Wall mounting bracket
FW1	Wall mounting bracket, Material 316L (1.4404)
TM	2" pipe mounting bracket
TM1	2" pipe mounting bracket, Material 316L (1.4404)
SS	Special range (Information is required by the customer)
SS_FLOW	Special range with square root graduation for flow indication (Information is required by the customer)
E6	Dial pin in 6 o'clock position
CS	Combination range / Dual scale

Liquid Filling

GR	Glycerine (standard)
GT	Korasilon® Oil M (only for magnetic spring contacts)
GV	Silicone 50 cSt
GX	Halocarbon®
QC	Glysantine system filling and silicone case filling for low ambient temperatures up to -40 °C
LJ	Hermetically sealed and field fillable

Electrical Connection

	Cable Box
HAN7D	Harting connection HAN 7D (not available for liquid filled cases)
M20	Cable gland M20x1,5

Static Pressure

PN160	Static pressure 160 bar
PN250	Static pressure 250 bar
PN400	Static pressure 400 bar (Only available for ranges > 600 mbar and without O-ring-option "PT")

Windows/Pointers

SG	Laminated safety glass (standard)
EP	Maximum pointer and polycarbonate window
EQ	Minimum pointer and polycarbonate window
PD	Polycarbonate window
SH	Red set hand stationary and polycarbonate window
SJ	Double red set hand stationary and polycarbonate window

Electrical Contacts

see data sheet K55

Contacts are available for execution with small chamber diaphragm $\varnothing 75$ mm and ranges ≥ 400 mbar
and for execution with large chamber diaphragm $\varnothing 130$ mm and ranges ≥ 100 mbar

MXXXX	Magnetic spring contact
IXXXX	Inductive contact
IXXXXSN	Inductive contact with safety design according to NAMUR
AO	Analog output 4-20 mA



F5503 Differential Pressure Gauge

ORDERING CODE	EXAMPLE:	100	F5503	S	-	51	L	1BR	XC3
Options (If choosing an option(s) must include a "X")									X_
Cleaning									
6B	Cleaned for oxygen service								
6W	Cleaned for oxidizing processes								
YF	Cleaned silicone free (not available for silicone filling)								
Marking/Tagging									
NH	Stainless steel tag, wired to case								
NH1	Extra large stainless steel tag, wired to case								
DA	Dial marking (Text marking on the dial)								
Testing/Certificates									
CD2	Material test report according to EN 10204 / 2.2								
C3	Material report according to EN 10204 / 3.1								C3
CD5	Certificate according to NACE for Oilfields MR0175 / ISO 15156 and Refineries MR0103 / ISO17945								
MQ	Positive Material Identification (PMI)								
MF	Free from Mercury contamination								
C4	Individual calibration chart								
HL	Helium leak test								
ML	Mass spectrometer leak test								
HY	Hydrostatic testing								
N1	Hydrostatic testing for gauge system								



F5503 Differential Pressure Gauge

STANDARD PRESSURE RANGE						
SMALL CHAMBER WITH Ø 75 MM CELL						
	RANGE	CODE	SEAL ASSEMBLY ³⁾	ELECTRICAL CONTACTS	AVAILABLE DIAPHRAGMS	NOTE
PN100 / PN160 / PN250 / PN400	0 ... 0,6 bar	0P6BR	✓	✓	DURATHERM [®] or Monel [®] 400 (2.4360) or Hastelloy [®] C-276	1)
	0 ... 1bar	1BR	✓	✓		1)
	0 ... 1,6 bar	1P6BR	✓	✓		1)
	0 ... 2,5 bar	2P5BR	✓	✓		1)
	0 ... 4 bar	4BR	✓	✓	DURATHERM [®] , Monel [®] 400 (2.4360) or Hastelloy [®] C-276 foil	1) 2)
	0 ... 6 bar	6BR	✓	✓		1) 2)
	0 ... 10 bar	10BR	✓	✓		1) 2)
	0 ... 16 bar	16BR	✓	✓		1) 2)
	0 ... 25 bar	25BR	✓	✓	Inconel [®] 718 (2.4668)	1) 2)
	0 ... 40 bar	40BR	✓	✓		
	-1 ... 0,6 bar	N1_OP6BR	✓	✓	DURATHERM [®] or Hastelloy [®] C-276	
	-1 ... 1,5 bar	N1_1P5BR	✓	✓		
	-1 ... 3 bar	N1_3BR	✓	✓		
	-1 ... 5 bar	N1_5BR	✓	✓		
LARGE CHAMBER WITH Ø 130 MM CELL						
PN100 / PN250	0 ... 25 mbar	25MB	✗	✗	Stainless steel 316Ti (1.4571) or Hastelloy [®] C-276	180° dial arc
	0 ... 40 mbar	40MB	✗	✗		
	0 ... 60 mbar	60MB	✗	✗		
PN100 / PN160 / PN250	0 ... 100 mbar	100MB	✗	✓		
	0 ... 160 mbar	160MB	✓	✓		4)
	0 ... 250 mbar	250MB	✓	✓		4)
	0 ... 400 mbar	400MB	✓	✓		4)
	-40 ... +60 mbar	N40_60MB	✗	✓		
	-60 ... +100 mbar	N60_100MB	✓	✓		4)
	-100 ... +150 mbar	N100_150MB	✓	✓		4)
	-100 ... +250 mbar	N100_250MB	✓	✓		4)

Note 1: Monel[®] diaphragm is only available for PN100 rating

Note 2: Hastelloy[®] C-276 diaphragm is only available for accuracy class 1,6

Note 3: The diaphragm seals must be designed with consideration to displacement volume, capillary length and application temperature.

Note 4: Consult Ashcroft Instruments GmbH for special adapted design



F5503 Differential Pressure Gauge

DIMENSIONS FOR Ø 75 MM CELL IN MM [INCH]

For reference only, consult Ashcroft for specific dimensional drawings

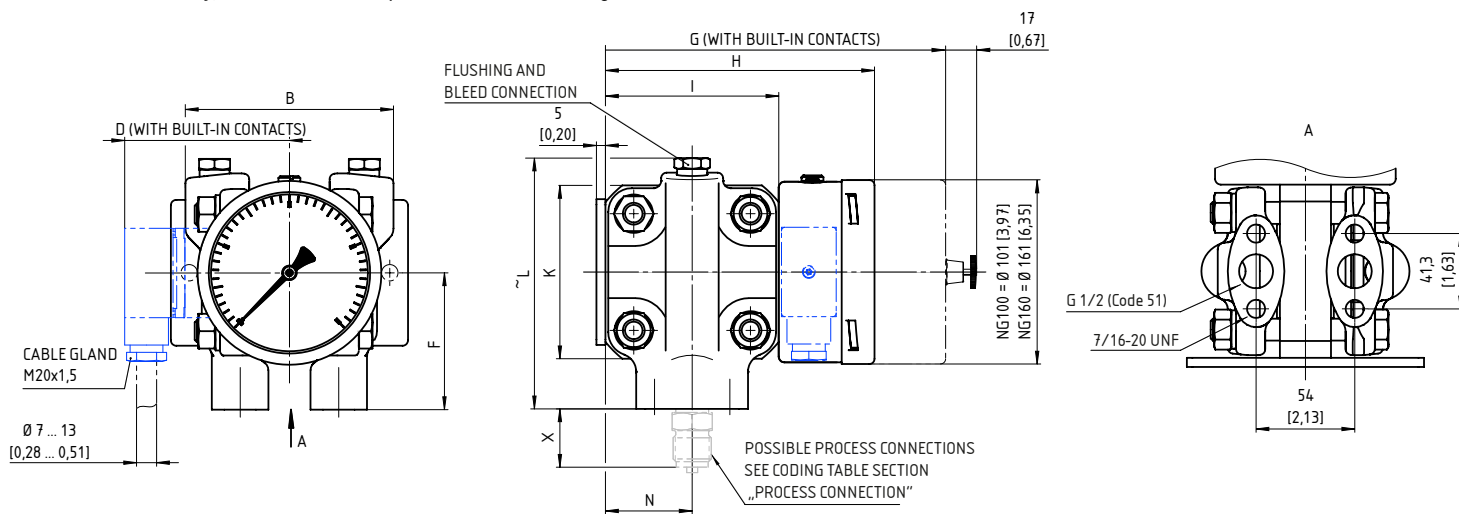

2" PIPE MOUNTING BRACKET „TM“

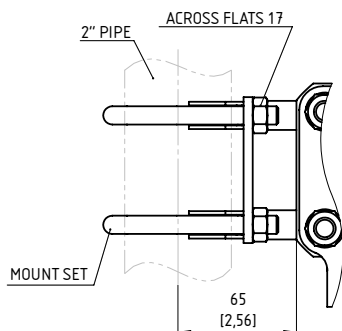

WALL MOUNTING PREPARATION „FW“
0,6 ... 40 bar / Ø 75 mm

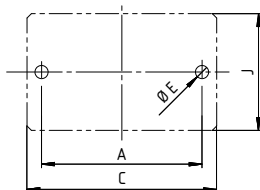

WALL MOUNTING PREPARATION „FW“
25 ... 400 mbar / Ø 130 mm

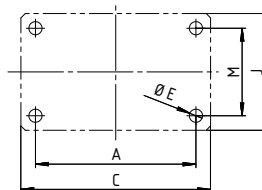

MEASURING PRINCIPLE

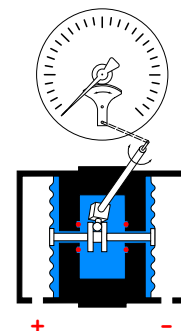

RANGE	PRESSURE RATING	DIAMETER CHAMBER	A	B	C	D	E	F	G	H	I	J	K	~L	M	N	WEIGHT (KG)
25 ... 400 mbar	PN100/ PN160	Ø 130 mm	132 [5,20]	108 [4,25]	152 [5,98]	120 [4,72]	4x Ø9 [0,35]	100 [3,94]	232,5 [9,15]	193,5 [7,62]	141 [5,55]	80 [3,15]	141 [5,55]	181 [7,11]	60 [2,36]	70,5 [2,78]	12,4
0,6 ... 40 bar	PN100	Ø 75 mm	110 [4,33]	114 [4,49]	130 [5,12]	90 [3,54]	2x Ø9 [0,35]	75 [2,95]	186,5 [7,34]	147,5 [5,81]	95 [3,74]	80 [3,15]	95 [3,74]	138 [5,41]	-	47,5 [1,87]	5,70
0,6 ... 40 bar	PN160	Ø 75 mm	110 [4,33]	114 [4,49]	130 [5,12]	90 [3,54]	2x Ø9 [0,35]	75 [2,95]	200,5 [7,89]	161,5 [6,36]	95 [3,74]	80 [3,15]	95 [3,74]	138 [5,41]	-	47,5 [1,87]	5,70

THREADS	STANDARD	CODE	THREAD LENGTH X	
			MATERIAL "S"	MATERIAL "HH"
¼-18 NPT MALE	DIN EN 837	02	33 [1,30]	33 [1,30]
½-14 NPT MALE	DIN EN 837	04	36 [1,42]	36 [1,42]
G ¼ B MALE	DIN EN 837	13	25 [0,98]	25 [0,98]
G ½ B MALE	DIN EN 837	15	32 [1,26]	32 [1,26]
M20x1,5 MALE	DIN 3852 Part 1	16	32 [1,26]	32 [1,26]
¼-18 NPT FEMALE		25	25 [0,98]	25 [0,98]
G ¼ FEMALE	DIN EN 837	27	15 [0,59]	15 [0,59]
½-14 NPT FEMALE		50	0	25 [0,98]
G ½ FEMALE		51	0	25 [0,98]



F5503 Differential Pressure Gauge

DIMENSIONS IN MM [INCH]

For reference only, consult Ashcroft for specific dimensional drawings

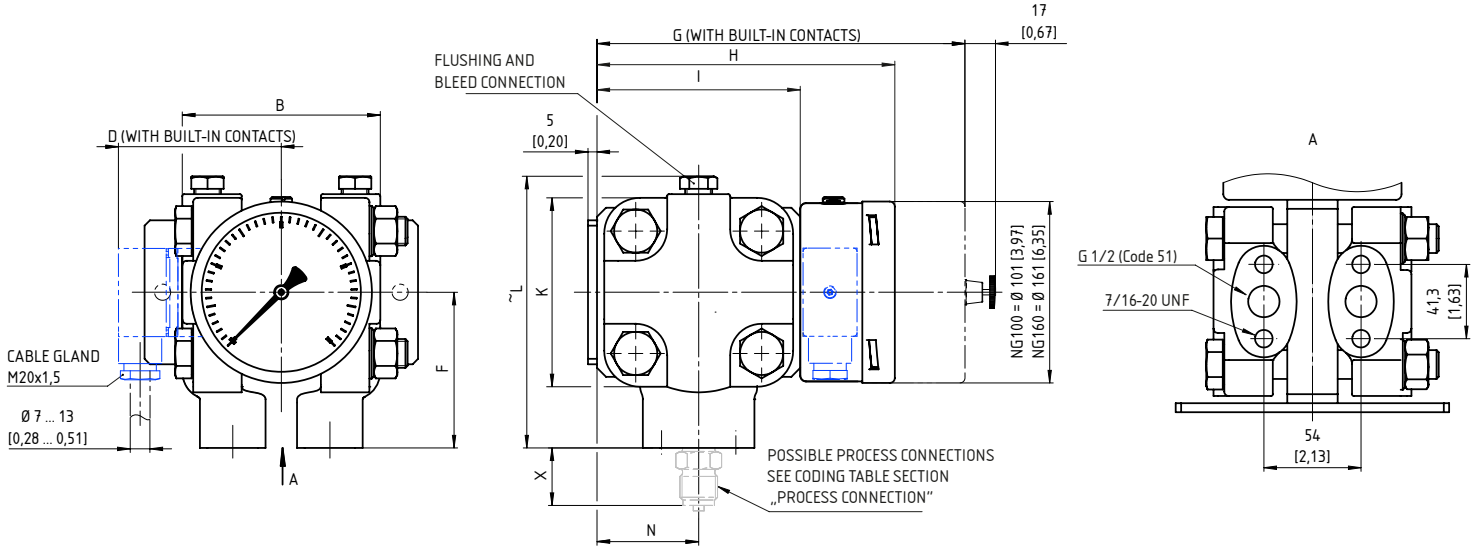

2" PIPE MOUNTING BRACKET „TM”

WALL MOUNTING PREPARATION „FW”
0,6 ... 40 bar / Ø 75 mm

WALL MOUNTING PREPARATION „FW”
25 ... 400 mbar / Ø 130 mm

MEASURING PRINCIPLE

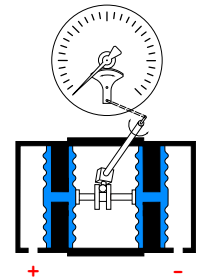
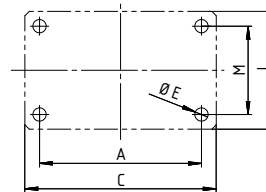
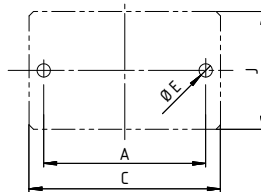
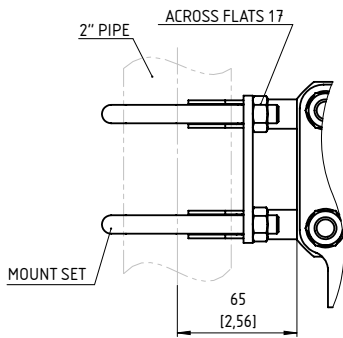

RANGE	PRESSURE RATING	DIAMETER CHAMBER	A	B	C	D	E	F	G	H	I	J	K	~L	M	N	WEIGHT (KG)
40 ... 400 mbar	PN250	Ø 130 mm	170 [6,69]	148 [5,83]	200 [7,87]	120 [4,72]	4x Ø11 [0,43]	120 [4,72]	273,5 [10,77]	227,5 [8,96]	175 [6,89]	100 [3,94]	170 [6,69]	219 [8,62]	60 [2,36]	87,5 [3,44]	28,5
0,6 ... 40 bar	PN250/ PN400	Ø 75 mm	132 [5,20]	110 [4,33]	152 [5,98]	90 [3,54]	2x Ø9 [0,35]	86,5 [3,41]	204,5 [8,05]	165,5 [6,52]	113 [4,45]	80 [3,15]	105 [4,13]	151 [5,94]	-	56,5 [2,22]	10,5

THREADS	STANDARD	CODE	THREAD LENGTH X	
			MATERIAL "S"	MATERIAL "HH"
¼-18 NPT MALE	DIN EN 837	02	33 [1,30]	33 [1,30]
½-14 NPT MALE	DIN EN 837	04	36 [1,42]	36 [1,42]
G ¼ B MALE	DIN EN 837	13	25 [0,98]	25 [0,98]
G ½ B MALE	DIN EN 837	15	32 [1,26]	32 [1,26]
M20x1,5 MALE	DIN 3852 Part 1	16	32 [1,26]	32 [1,26]
¼-18 NPT FEMALE		25	25 [0,98]	25 [0,98]
G ¼ FEMALE	DIN EN 837	27	15 [0,59]	15 [0,59]
½-14 NPT FEMAL		50	0	25 [0,98]
G ½ FEMALE		51	0	25 [0,98]

