

Size DN	PRESSURE CLASSES	ØD	b	ØdM	Øk	Øl	H	WEIGHT KG
1"	150	[4,33] 110	[0,58] 14,7	[1,26] 32	[3,13] 79,4	[0,63] 15,9 x 4	[2,29] 58,2	1,2
	300	[4,92] 125	[0,71] 17,9		[3,50] 88,9	[0,75] 19,1 x 4	[2,42] 61,4	1,8
	400/600	[0,97] 24,5	[2,68] 68,0		[4,00] 101,6	[1,00]	[3,11] 79,1	4,7
	900/1500	[5,91] 150	[1,40] 35,6		[4,25] 108,0	25,4 x 4	[3,37] 85,5	7,0
	2500	[6,30] 160	[1,65] 42,0		[3,87] 98,4	[0,63] 15,9 x 4	[2,42] 61,4	1,8
1 1/2"	150	[4,92] 125	[0,71] 17,9	[1,73] 44	[3,87] 98,4	[0,63] 15,9 x 4	[2,42] 61,4	1,8
	300	[6,10] 155	[0,83] 21,1		[4,50] 114,3	[0,87] 22,2 x 4	[2,54] 64,6	3,1
	400/600	[1,15] 29,3	[2,87] 72,8		[4,87] 123,8	[1,13] 28,6 x 4	[3,24] 82,3	7,3
	900/1500	[7,09] 180	[1,53] 38,8		[5,75] 146,0	[1,25] 31,8 x 4	[3,74] 95,0	12,5
	2500	[8,07] 205	[2,03] 51,5		[4,75] 120,7	[0,75] 19,1 x 4	[2,48] 63,0	2,8
2"	150	[5,91] 150	[0,77] 19,5	[2,24] 57	[5,00] 127,0	[0,75] 19,1 x 8	[2,62] 66,5	3,7
	300	[6,50] 165	[0,89] 22,7		[6,50] 165,1	[1,00] 25,4 x 8	[3,49] 88,6	11,8
	400/600	[1,28] 32,4	[2,99] 75,9		[6,75] 171,4	[1,13] 28,6 x 8	[3,99] 101,4	17,9
	900/1500	[8,46] 215	[1,78] 45,1		[6,00] 152,4	[0,75] 19,1 x 4	[2,67] 67,8	5,5
	2500	[9,25] 235	[2,28] 57,9		[6,63] 168,3	[0,87] 22,2 x 8	[2,85] 72,5	7,5
3"	150	[7,48] 190	[0,96] 24,3	[3,46] 88	[7,50] 190,5	[0,75] 19,1 x 8	[2,67] 67,8	7,8
	300	[8,27] 210	[1,14] 29,0		[7,87] 200,0	[0,87] 22,2 x 8	[2,98] 75,7	12,6
	400/600	[1,53] 38,8	[3,25] 82,5		[8,50] 215,9	[1,00] 25,4 x 8	[3,37] 85,5	16,3
	900	[9,45] 240	[1,78] 45,1		[9,25] 235,0	[1,25] 31,8 x 8	[3,74] 95	24,8
	1500	[10,43] 265	[2,15] 54,7		[9,50] 241,3	[1,37] 34,9 x 8	[4,11] 104,5	33,3
	2500	[12,01] 305	[2,90] 73,7		[10,75] 273,0	[1,63] 41,3 x 8	[4,99] 126,7	58,9
4"	150	[9,06] 230	[0,96] 24,3	[3,46] 88	[7,50] 190,5	[0,75] 19,1 x 8	[2,67] 67,8	7,8
	300	[10,04] 255	[1,27] 32,2		[7,87] 200,0	[0,87] 22,2 x 8	[2,98] 75,7	12,6
	400	[1,65] 42,0	[3,37] 85,5		[8,50] 215,9	[1,00] 25,4 x 8	[3,49] 88,6	21,6
	600	[10,83] 275	[1,78] 45,1		[9,25] 235,0	[1,25] 31,8 x 8	[3,74] 95	24,8
	900	[11,42] 290	[2,03] 51,5		[9,50] 241,3	[1,37] 34,9 x 8	[4,11] 104,5	33,3
	1500	[12,20] 310	[2,40] 61,0		[10,75] 273,0	[1,63] 41,3 x 8	[4,99] 126,7	58,9

INSTRUMENT CONN. THREADS	CODE
1/4-18 NPT FEMALE	02T
1/2-14 NPT FEMALE	04T
G 1/2 FEMALE; DIN EN 837	51T
G 1/4 FEMALE; DIN EN 837	26T
WELDING PORT	00T

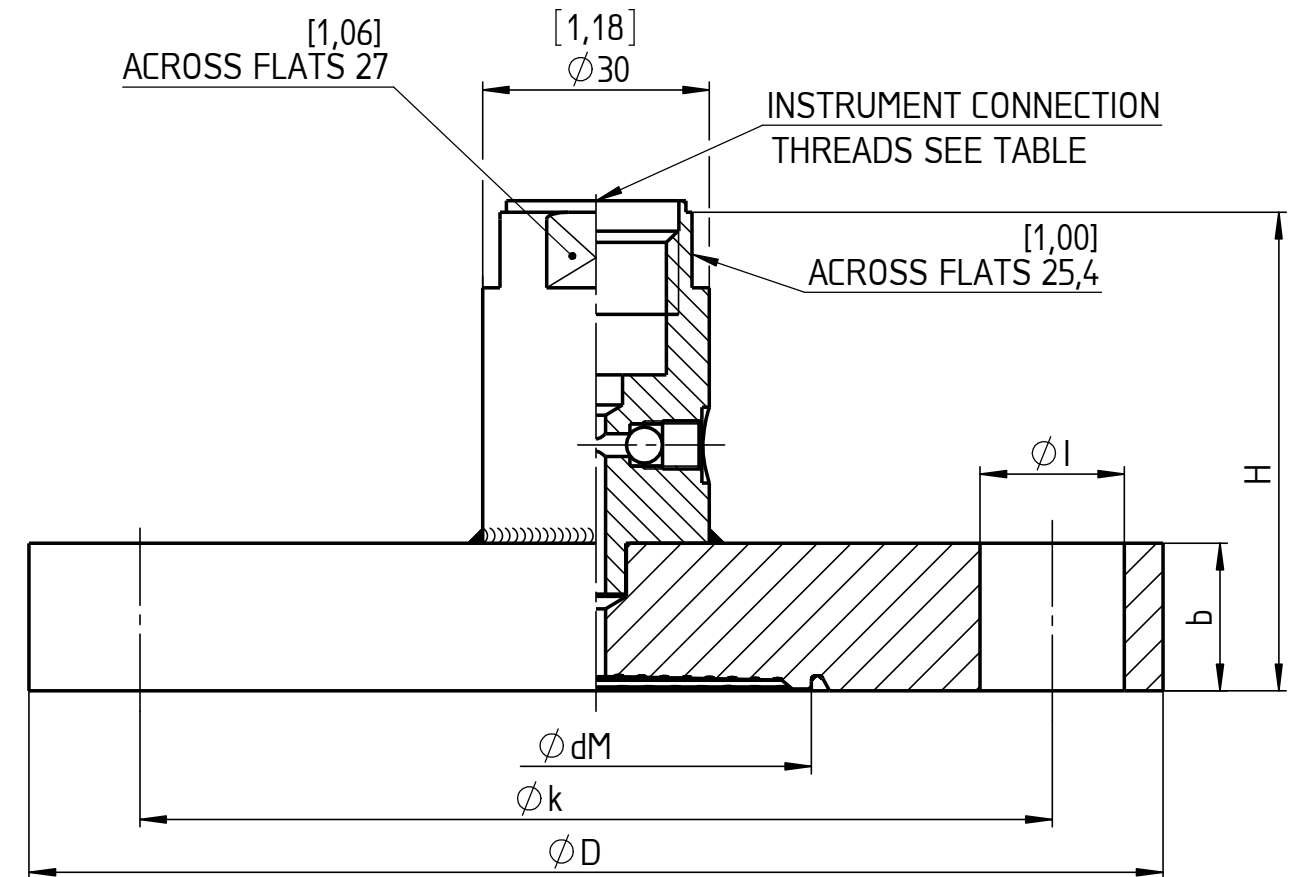

This drawing includes confidential information which is the property of ASHCROFT INC. This copy is loaned for a specific purpose, with the understanding that it will not be reproduced or used for any other purpose or disclosed to others, and it will be returned on demand.				Dimensions in mm [inch]			
				General Dimension			
				Seal DF_ANSI, FF			
				Date	Name		
				Drawn 30.01.15	J. Krott		
				Checked 20.08.20	Th. Wel		
B	Tabelle updated	20.08.20	Krott				
A	Øl added,						
	Tabelle updated	15.07.16	Koll.				
Rev.	Description	Date	Na.				
						DWG. NO. B 076 I 3-DF_ASME-FF	

All specifications are subject to change without notice.