

TWO WIRE 4-20 MA LOOP POWERED ANALOG OUTPUT

This product information page illustrates the benefits of 4-20 mA loop analog output and the most common commissioning problems. The majority of Ashcroft transducers and transmitters offer a 4-20mA loop powered two-wire analog output. The 4-20 mA current loop consists of a transmitter, power supply and SCADA, PLC, DCS or other monitoring devices wired in series.

PIP #: TR-PI-107

Applicable to:
4-20mA loop
Analog Output

Advantages:

- Popular and robust output signal with low electromagnetic interference.
- Can be run over long distances with minimal signal losses.
- Easy installation and verification since zero process corresponds to 4 mA output. This will allow system verification without initiating the process.
- Only positive and negative connections to the current loop are required. In contrast to three wire setups where an external power supply is required.
- The only advantage of a three wire system is that they will allow higher resistance loads. For example, the current loop can be operated on a measuring instrument with higher input impedance.
- Current output can be converted to voltage output at any point in the circuit by adding a load resistor in series. The voltage drop across the resistor will vary proportionally with process. For instance, a 250-ohms resistor will produce a 1 to 5-volt output signal with 4-20mA current loop signal.
- See figure 1 below of a two wire loop powered transmitter and figure 2 loop resistance calculation method for reference.

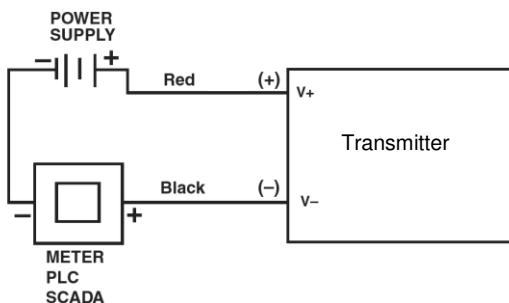

Figure 1 Two wire Loop power transmitter

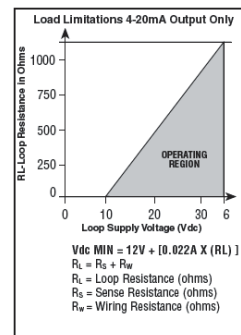

Figure 2 Loop resistance calculation

Most Common Commissioning Problems:

A 4-20 mA signal can travel over long cable distances with minimal signal losses. The long cable may induce a voltage drop at the transmitter input beyond the transmitter specifications.

The most common problem is insufficient voltage at the transmitter due to voltage drop around the loop. Specifically, at full scale operation. The required 20 mA of current cannot be reached, if the supply voltage to the current loop is too low. The SCADA, PLC, DCS system or other receivers will not detect insufficient voltage and the measured current will be used as a normal value. That, can cause serious problems in the system operation. Alarms, valves and safety shutdown features will not function if the trip levels are not reached. It is essential to sustain minimum required voltage but it is also important not to exceed the maximum specified voltage. since that may lead to system failure or internal heating of the system. See figure 2 to calculate loop resistance and to determine that adequate voltage is supplied to the loop.