

A-Series Miniature Explosion Proof Pressure Switches

FEATURES

- Compact size
- 316 Stainless steel construction
- Pressure ranges from vacuum to 15,000 psi
- Field adjustable setpoint or factory set only
- Wide operating temperature range (-40 to 89 °C) max.
- Hermetically sealed micro switch
- Precision snap-acting micro switch element
- SPDT or DPDT switching
- SIL 3 capable
- Dual-seal rated

TYPICAL USES

- Refineries
- Chemical and Petrochemical Plants
- Offshore Oil Rigs
- Oil & Gas Production



A-Series
Explosion Proof
Pressure Switch

SPECIFICATIONS

Setpoint:	Factory set or field adjustable
Setpoint Repeatability:	±2% of span. For ranges 200 through 15,000 psi ±5% of span. For ranges -15/15 through 100 psi (additional setpoint shift ±2% of span per 40 °F from initial setpoint setpoint at 70 °F typical)
Vibration:	Passed MIL-STD-202G
Shock:	75G's 10 milliseconds 3 axis
Piston:	Stainless steel w/Viton™ or Buna-N O-ring
Mechanical life piston design:	>1,000,000 operations typical
Diaphragm:	316L Stainless steel
Mechanical life diaphragm design:	>400,000 operations typical
Enclosure material:	316L Stainless steel
Enclosure rating:	NEMA 4X, 7, 9, IP 67
Pressure Connection:	1/8 NPTF, 1/4 NPTF, 1/4 Male fixed compatible with VCR® or VCO® fittings, NPTM, 1/8 NPTM, 1/2 MNPT, 1/2 FNPT, 7/16-20 SAE M, 1/4 Male fixed compatible with VCO® or VCR® fittings, 3/4" Tri-Clamp®, 1.5" Tri-Clover®, 2.0" Tri-Clover® G1/4 B, G1/4 A Type E Stub end
Electrical Output:	SPDT, or DPDT 5A or 3A 120VAC, 2A @ 30 VDC, 5A @ 28 VAC, gold contacts available
Electrical Termination:	18 AWG wire leads, with 1/2 NPT male conduit connection, 18 AWG wire leads, with M20 x 1.5 male conduit connection



KEY BENEFITS

- Small size
- Good for hazardous and corrosive applications
- Easily configurable to meet your application requirements
- SIL 3 capable

Approvals: UL, CSA, CE, CRN, SIL 3 capable, RoHS, FM, ATEX, IECEx, Dual Seal





 CLASS I DIV 1 GROUPS A, B, C, & D
 CLASS II DIV 1 GROUPS E, F, & G
 T5 or T6 – see Material and Temperature Range Table

 Sira 13ATEX1123X IECEx
 CSAE 21UKEX1055X CSA 13.0015X
 Ex d IIC T6/T5 Gb
 Ex tb IIIC T85°C/100°C Db
 T5 or T6 – see Material and Temperature Range Table

Dual Seal

The A- series explosion proof pressure switch is designed to meet the requirements of ANSI/ISA-12.27.01-2003 for process sealing between electrical systems and flammable or combustible material.

A-Series Miniature Explosion Proof Pressure Switches

CHARACTERISTICS AND RATINGS

A SERIES SWITCH PERFORMANCE CHARACTERISTICS												
RANGE (Ordering Code)			SETPOINT REPEATABILITY			SETPOINT ADJUSTABILITY			DEADBAND (DB)			
	psi (#)	bar, kg/cm2 (BAR) (KSC)	kPa (KP)	psi	bar, kg/cm2	kPa	psi	bar, kg/cm2	kPa	psi	bar, kg/cm2	kPa
DIAPHRAGM	-15/15	-1/1	-100/100	±1.5	±.10	±10	-15/15	-1/1	-100/100	1-5	0.07-.35	7-35
	30	2	200	±1.5	±.10	±10	6-30	0.4-2	6-200	1-5	0.07-.35	7-35
	60	4	400	±3.0	±.21	±21	8-60	0.6-4	60-400	2-10	0.14-.70	14-70
	100	7	700	±5.0	±.34	±34	10-100	0.7-7	70-700	3-15	0.2-1.0	20-100
	200	14	1400	±4	±.28	±28	20-200	1.4-14	140-1,400	3-30	0.2-2.0	20-200
PISTON	100	7	700	±5.0	±.34	±34	20-100	1.4-7	140-700	3-15	0.2-1.0	20-100
	200	14	400	±4	±.28	±28	40-200	2.8-14	280-1,400	3-30	0.2-2.0	20-200
	500	35	3500	±10	±.70	±70	50-500	3.5-35	350-3,500	20-100	1.4-7.0	140-700
	1000	70	7000	±20	±1.40	±140	100-1,000	7-70	700-7,000	25-150	1.7-10	170-1,000
	2000	140	14000	±40	±2.8	±280	200-2,000	14-140	1,400-14,000	30-300	2-20	200-2,000
	5000	350	35000	±100	±7.0	±700	500-5,000	35-350	3,500-35,000	75-750	5-50	50-5,000
	7500	500	50000	±150	±10	±1,000	750-7,500	50-500	5,000-50,000	110-1,100	7.5-75	750-7,500
	10000	700	70000	±200	±14.0	±1,400	100-10,000	70-700	7,000-70,000	250-2,500	17-170	1,700-1,700
	15000	1000	10000	±300	±20	±2,000	1,500-15,000	100-1,000	10,000-100,000	300-3,000	20-200	200-20,000

ELECTRIC		OPTIONS				PRESSURE RANGE				
Switch Code	Electric on Label	Code	Description			Actuator	psi	Bar	kPa	Kg/cm ²
1P	3A 125Vac; 2A, 30Vdc	C4	Traceable calibration certificate			S	-15/15#	-1/1BR	-100/100KP	-1/1KSC
		FP	Fungus proofing			S	30#	2BR	200KP	2KSC
		MQ	Positive Material Identification (75, 15 & 20 process conn. only)			S	60#	4BR	400KP	4KSC
1H, 2H	5A 125/250Vac; 5A, 28Vdc	NC	2 wire leads w/ground wire – wired for normally closed operation			B, S, V	100#	7BR	700KP	7KSC
		NO	2 wire leads w/ground wire – wired for normally open operation			B, S, V	200#	14BR	1,400KP	14KSC
1G	0.1A 125Vac; 0.1A 30Vdc	NH	Stainless steel tag			B, V	500#	35BR	3,500KP	35KSC
		NN	Paper tag			B, V	1,000#	70BR	7,000KP	70KSC
		6B	Cleaned for oxygen service			B, V	2,000#	140BR	14,000KP	140KSC
1L, 2L	1A 125Vac; 1A 28Vdc	GO	No ground wire			B, V	5,000#	350BR	35,000KP	350KSC
						B, V	7,500#	500BR	50,000KP	500KSC
						B, V	10,000#	690BR	70,000KP	700KSC
						B, V	15,000#	1,000BR	100,000KP	1,000KSC

MATERIAL AND TEMPERATURE RATINGS (based on material and switch code)							
Switch CODE	with MAT'L CODE	MATERIAL	TEMP. MIN	T5 Ta MAX	T5 Tp MAX	T6 Ta MAX	T Tp MAX
1H, 2H, 1L, 2L	S	316 SS	-40 °F (-40 °C)	192 °F (89 °C)	192 °F (89 °C)	165 °F (74 °C)	165 °F (74 °C)
1H, 2H, 1L, 2L	B (Ranges 500-7500#)	316 SS, BUNA	-40 °F (-40 °C)	192 °F (89 °C)	192 °F (89 °C)	165 °F (74 °C)	165 °F (74 °C)
1H, 2H, 1L, 2L	B (Ranges 100, 200, 10k, 15k)	316 SS, BUNA	-4 °F (-20 °C)	192 °F (89 °C)	192 °F (89 °C)	165 °F (74 °C)	165 °F (74 °C)
1H, 2H, 1L, 2L	V	316 SS, VITON™	-4 °F (-20 °C)	192 °F (89 °C)	192 °F (89 °C)	165 °F (74 °C)	165 °F (74 °C)
1H, 2H, 1L, 2L	N (Ranges 500-7500#)	316 SS, HNBR	-40 °F (-40 °C)	192 °F (89 °C)	192 °F (89 °C)	165 °F (74 °C)	165 °F (74 °C)
1H, 2H, 1L, 2L	N (Ranges 10k, 15k)	316 SS, HNBR	-4 °F (-20 °C)	192 °F (89 °C)	192 °F (89 °C)	165 °F (74 °C)	165 °F (74 °C)
1P, 1G	S	316 SS	-4 °F (-20 °C)	165 °F (74 °C)	165 °F (74 °C)	165 °F (74 °C)	165 °F (74 °C)
1P, 1G	B	316 SS, BUNA	-4 °F (-20 °C)	165 °F (74 °C)	165 °F (74 °C)	165 °F (74 °C)	165 °F (74 °C)
1P, 1G	V	316 SS, VITON™	-4 °F (-20 °C)	165 °F (74 °C)	165 °F (74 °C)	165 °F (74 °C)	165 °F (74 °C)
1P, 1G	N	316 SS, HNBR	-4 °F (-20 °C)	165 °F (74 °C)	165 °F (74 °C)	165 °F (74 °C)	165 °F (74 °C)

PRESSURE RATINGS										
CONFIGURATION		MAX. WORKING PRESSURE "MWP"			PROOF PRESSURE "PROOF"			BURST PRESSURE		
RANGES (psi)	w/SEAL	psi	bar, kg/cm2	kPa	psi	bar, kg/cm2	kPa	psi	bar, kg/cm2	kPa
up to 200	S	800	55	5,500	1,000	70	7,000	>9,500	>655	>65,500
100-200	B, V or N	2,000	140	14,000	2,000	140	14,000	>10,000	>700	>70,000
500-2,000	B, V or N	5,000	350	35,000	8,000	550	55,000	>30,000	>2,100	>210,000
5,000-7,500	B, V or N	10,000	700	70,000	15,000	1,000	100,000	>50,000	>3,500	>350,000
10,000-15,000	B, V or N	15,000	1,000	100,000	20,000	1,400	140,000	>45,000	>31,000	>310,000

All specifications are subject to change without notice. All sales subject to standard terms and conditions. Ashcroft® and Trust the Shield® are trademarks of Ashcroft Inc. The following non-Ashcroft trademarks are the property of their respective owners: Tri-Clamp®, Tri-Clover®, VCO®, VCR®, Viton™.

For more information, see [Ashcroft Brands & Trademarks](#)

©2022 Ashcroft Inc. aexp_switch_ds_RevH_09-13-22

A-Series Miniature Explosion Proof Pressure Switches

ORDERING CODE	Example:	APS	N7	1	H	012C	S	02	30#	15	R	-X6B
Function												
APS - Pressure switch, single setpoint, fixed deadband, factory set, not field adjustable		APS										
APA - Pressure switch, single setpoint, fixed deadband, factory set, field adjustable												
Enclosure												
N7 - Explosion proof 316 SS			N7									
Micro Switch, First Character												
1 - Single switch, SPDT				1								
2 - Dual switch - DPDT (N4 - not available with "S" actuator < 100 psi, range, N7 - not available with "S" actuator or P&G micro switch)												
Micro Switch, Second Character												
G - Gold contact - 0.1A @ 125 Vac, 0.1A @ 30 Vdc												
H - High current - 5A @ 125/250 Vac, 5A @ 28 Vdc resistive, 3A @ 28 Vdc inductive					H							
L - High current, gold contact - 1A @ 125 Vac, 1A @ 28 Vdc resistive, 0.5A @ 28 Vdc inductive												
P - General purpose - 3A @ 125 Vac, 2A @ 30 Vdc												
Electrical Connection												
___ C - ½ NPT Male conduit with 18 AWG wires (Note ___ e.g. 012C = 12" lead wires, Specify wire length in inches)						012C						
___ G - M20 X 1.5 Male conduit connection with 18 AWG wires (Note ___ e.g. 012G = 12" lead wires, Specify wire length in inches)												
Actuator Seal (see page 6 for more information)												
B - 316 SS piston & Buna-N O-ring, ranges ≥ 100 psi												
V - 316 SS piston & Viton™ O-ring, ranges ≥ 100 psi												
S - 316 SS welded diaphragm, ranges ≤ 200 psi							S					
N - 316 SS piston & HNBR O-ring, ranges ≥ 100 psi												
Process Connection												
01 - ½ NPT Male												
02 - ¼ NPT Male								02				
03 - ½ NPT Female (not available for B, V, N actuators)												
04 - ½ NPT Male												
05 - 7/16-20 SAE Male												
06 - ¼ Male fixed compatible with VCR® fittings (not available for B, V, N actuators)												
07 - ¼ Male fixed compatible with VCO® fittings (not available for B, V, N actuators)												
08 - 7/16-20 SAE Female												
12 - G ¼ A (Type E Stud End)												
13 - G ¼ B												
25 - ¼ NPT Female (not available for B, V, N actuators)												
50 - ½ NPT Female												
46 - 9/16-SAE Female												
76 - 7/16-20 SAE w/37° flare end												
75 - ¾ Tri-Clamp® connection (includes 3A approval), range ≤ 1,000 psi												
15 - 1½ Tri-Clamp® connection (includes 3A approval), range ≤ 1,000 psi												
20 - 2.0 Tri-Clamp® connection (includes 3A approval), range ≤ 1,000 psi												
Ranges (select from tables on page 2 for additional ranges)												
30# - 30 psi									30#			
Setpoint												
15 - 5 Characters maximum representing setpoint of the switch in the same units as the ranges of the switch. For setpoints in vacuum specify as "-" pressure. If no set point is required on an APA switch use either "NSR" or "NSD". If direction is not known use "NSR" as default										15		
Setpoint Direction												
R - Rising pressure (increasing pressure, decreasing vacuum)											R	
D - Decreasing pressure (decreasing pressure, increasing vacuum)												
Options (select from table on page 2 (If choosing an option(s) must include an "X")												
6B - Cleaned for oxygen service												-X_
												6B

A-Series Miniature Explosion Proof Pressure Switches

DIMENSIONS

For reference only, consult Ashcroft for specific dimensional drawings

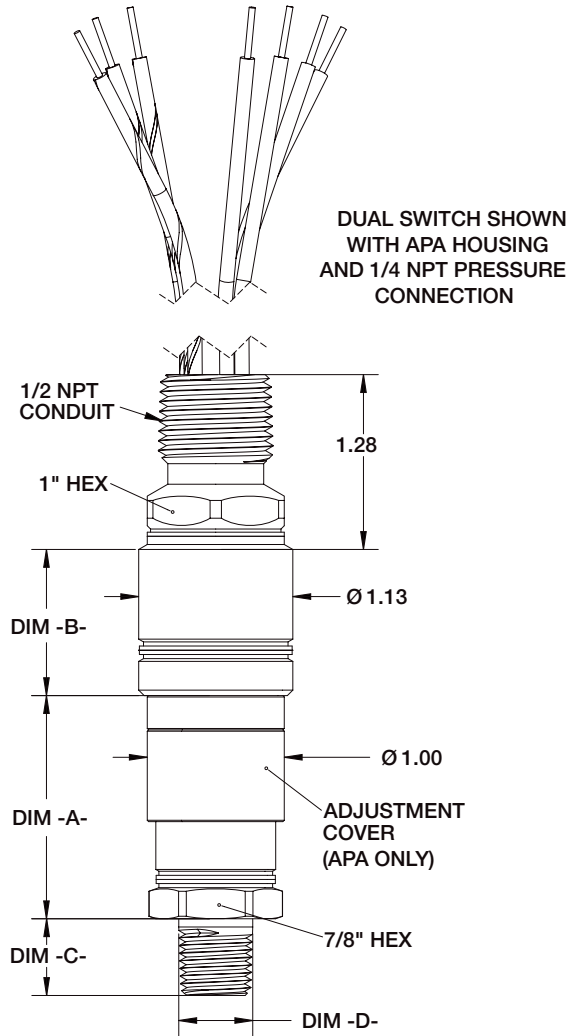

FUNCTION CODE

Description	Dim.A
APS (Factory Set)	1.06
APA (Field Adjustable)	1.64







MICRO SWITCH

Description	Dim.B
1H, 2H, 1L, 2L	1.03
1P, 1G	0.90

PRESSURE CONNECTION GENERAL DIMENSION

Code	Description	Dim.C	Dim.D
01	1/8 NPT Male	0.45	0.44
02	1/4 NPT Female	0.56	0.54
03	1/8 NPT Female	0.75	0.65
04	1/2 NPT Male	0.92	0.75
25	1/4 NPT Female	1.10	0.75
50	1/2 NPT Female	1.25	1.04
05	3/16-20 SAE Male	0.56	0.44
08	7/16-20 SAE Female	1.10	0.84
06	1/4 Male fixed compatible with VCR® fittings	0.58	0.56
07	1/4 Male fixed compatible with VCO® fittings	0.47	0.56
12	G 1/4A	0.47	0.44
13	G 1/4B	0.59	0.37
46	3/16-18 SAE Female	0.39	0.47
76	7/16-20 SAE w/37° Flare End	0.55	0.36
75	3/4" Tri-Clamp™ Seal	1.10	0.96
15	1 1/2" Tri-Clover™ Seal	1.23	1.99
20	2.0" Tri-Clover™ Seal	1.23	2.49

APPROVALS

	CRN: OF 14836.5C,
	CSA: 2454057 (LR55528)
	UL: E38812
	CE
	ROHS
	UKCA

A-Series Miniature Explosion Proof Pressure Switches

AVAILABLE CONNECTIONS

Pressure Connections

1/8, 1/4 or 1/2 MALE NPT



1/8 or 1/4 FEMALE NPT,
7/16-20 SAE FEMALE



1/4 MALE FIXED COMPATIBLE
with VCR® or VCO® FITTINGS



7/16-20 SAE MALE (OPTIONAL
37° FLARE END)



3/4", 1.5" or 2.0" SANITARY



G 1/4 A TYPE-E STUD END



1/2 FEMALE NPT



G 1/4 B



Electrical Connections

1/2 NPT CONDUIT
CONNECTOR WITH 18
AWG WIRE LEADS

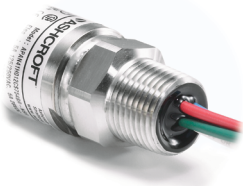

M20 X 1.5 MALE CONDUIT
WITH 18 AWG WIRES

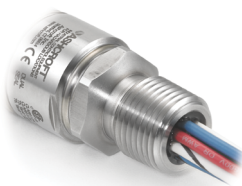

A-Series Miniature Explosion Proof Pressure Switches

SELECTION GUIDE

Before selecting a switch the following should be considered:

Actuator:

The actuator responds to changes in pressure and operates the micro switch element in response to these changes. The actuator is normally exposed to the process media and must be chemically compatible with it. There are three types of actuators available for the A-Series switches – all welded 316 SS diaphragm sealed piston; 316 SS piston with Viton™ O-ring seal; and 316 SS piston with Buna-N O-ring seal. The 316 SS diaphragm is available in ranges from -15/15 psi to 200 psi. The 316 SS piston is available in ranges from 100 psi to 15,000 psi. Switches offered in 100 psi and 200 psi can be ordered with either the piston or diaphragm design. The piston design will have a longer mechanical life, while the diaphragm design has a better operating temperature.

The piston design is more reliable than a diaphragm design when subjected to frequent large pressure excursions, pressure surges and spikes associated with typical hydraulic applications. Piston designs are typically used when the switch is used as low pressure alarm or cutoff where the normal working pressure is above the nominal range of the switch.

The Switching Function:

Most applications for alarm, shutdown and interlock are satisfied by the standard A-Series switches that feature single setpoint fixed deadband. For pump, compressor and other control applications, the dead-band becomes a very important consideration and may require increasing the range of the switch to increase the deadband. Please consult your Ashcroft representative for assistance with special applications.

The Micro Switch Element:

The micro switch element must be chosen to meet the electrical load requirement to be switched. The switches are offered as either SPDT (single pole double throw) or DPDT (double pole double throw). The DPDT switch is made up of two SPDT switches which are adjusted to work together by Ashcroft's patent-pending Circuit Board Rotation Design. DPDT switching is not available on diaphragm designs below 100 psi, with Spade terminals or the Micro DIN connector.

Understanding Setpoints and Reset Points:

Pressure switches can be set to switch on either increasing (rising) or decreasing pressures. Since the switches have both Normally Open (NO) contacts and Normally Closed (NC) contacts you can wire the switch to open or close for either an increasing or decreasing pressure. To be consistent in setting the switches Ashcroft defines the setpoints as follows: For an increasing setpoint, the pressure is increased from 0 psi to the set point and then decreased to the reset point. For a decreasing setpoint, the pressure is increased to full range and then decreased to the setpoint and then increased to the resetpoint.

Custom Applications:

The A-series switch is designed to allow custom process connections and electrical terminations. Please consult your Ashcroft representative for assistance with custom applications.

Cutaway view of switch assembly with welded SS diaphragm

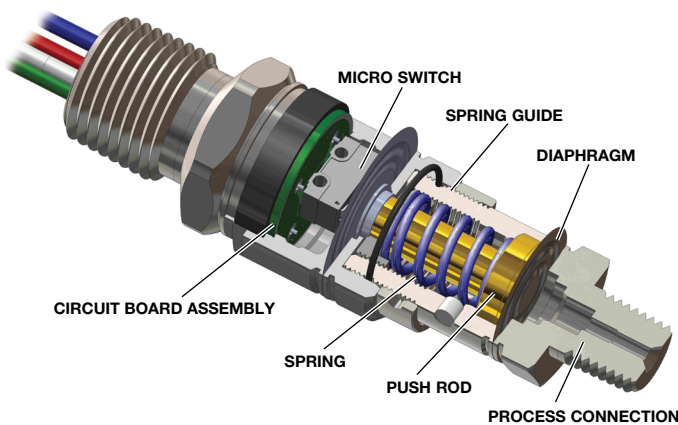

Cutaway view of switch assembly with SS piston

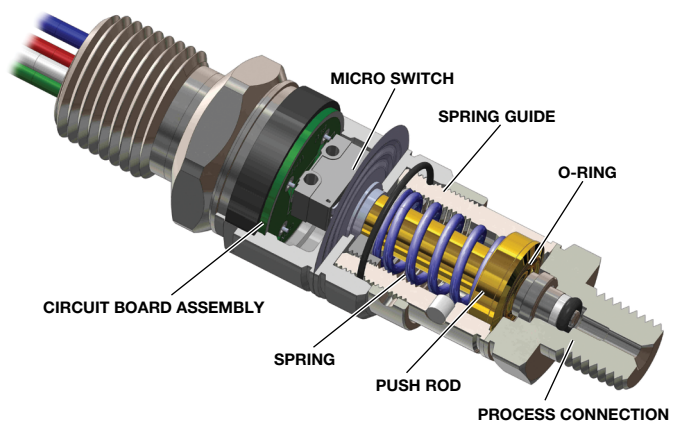

A-Series Miniature Explosion Proof Pressure Switches

ADDITIONAL SWITCH TERMINOLOGY

Accuracy – (See repeatability) Accuracy normally refers to conformity of an indicated value to an accepted standard value. There is no indication in switch products; thus, instead, the term repeatability is used as the key performance measure.

Automatic Reset Switch – Switch which returns to normal state when actuating variable Pressure is reduced.

Adjustable or Operating Range – That part of the nominal range over which the switch setpoint may be adjusted. Normally about 10% to 100% of the nominal range for A-Series pressure switches.

Burst Pressure – The maximum pressure that may be applied to a pressure switch without causing leakage or rupture. This is approximately 16X of nominal range for A-Series switches. Diaphragm switches subjected to pressures above the nominal range can be permanently damaged.

Deadband – The difference between the setpoint and the resetpoint, normally expressed in units of the actuating variable. Sometimes referred to as differential.

Fixed Deadband – The difference between the setpoint and the resetpoint of a pressure switch. It further signifies that this deadband is a fixed function of the pressure switch and not adjustable.

National Electrical Manufacturers Association (NEMA) – This group has defined several categories of enclosures, usually referred to as “types.” Further, they designate certain features and capabilities each type must include.

NEMA 4X – Type 4X enclosures are intended for indoor and outdoor use primarily to provide a degree of protection against corrosion, windblown dust and rain, splashing water, and hose directed water; and to be undamaged by the formation of ice on the enclosure.

NEMA 7 – Type 7 enclosures are for indoor use in locations classified as Class I, Groups A, B, C, or D, as defined in the National Electrical Code. Type 7 enclosures shall be capable of withstanding the pressures resulting from an internal explosion of specified gases, and contain such an explosion sufficiently that an explosive gas-air mixture existing in the atmosphere surrounding the enclosure will not be ignited. Enclosed heat generating devices shall not cause external surfaces to reach temperatures capable of igniting explosive gas-air mixtures in the surrounding atmosphere.

NEMA 9 – Type 9 enclosures are intended for indoor use in locations classified as Class II, Groups E, F, or G, as defined in the National Electrical Code. Type 9 enclosures shall be capable of preventing the entrance of dust. Enclosed heat generating devices shall not cause external surfaces to reach temperatures capable of igniting or discoloring dust on the enclosure or igniting dust-air mixtures in the surrounding atmosphere.

Normal Switch Position – Contact position before actuating pressure (or variable) is applied. Normally closed contacts open when the switch is actuated. Normally open contacts close when the switch is actuated.

Normally Closed – Refers to switch contacts that are closed in the normal switch state or position (unactuated). A pressure change opens the contacts.

Normally Open Switch – Refers to the contacts that are open in the normal switch state or position (unactuated). A pressure change closes the contacts.

Overpressure Rating(s) – A nonspecific term that could refer to either burst or proof pressure, or both.

Proof Pressure – The maximum pressure which may be applied without causing damage. This is determined under strict laboratory conditions including controlled rate of change and temperature: This value is for reference only. Consult factory for applications where switch must operate at pressures above nominal range or reference temperature (70 °F).

Repeatability (Accuracy) – The closeness of agreement among a number of consecutive measurements of the output setpoint for the same value of the input under the same operating conditions, approaching from the same direction, for full-range traverses. *Note:* It is usually measured as non-repeatability and expressed as repeatability in percent of span or nominal range. It does not include hysteresis or deadband.

Resetpoint – The resetpoint is the pressure value where the electrical switch contacts will return to their original or normal position after the switch has activated.

Setpoint – The setpoint is the pressure value at which the electrical circuit of a switch will change state or actuate. It should be specified either on increase or decrease of that variable.

Single Pole Double Throw (SPDT) Switching Element – A SPDT switching element has one normally open, one normally closed, and one common terminal. The switch can be wired with the circuit either normally open (N/O) or normally closed (N/C). SPDT is standard with A-series switches.

Double Pole Double Throw (DPDT) Switching Element – Two SPDT switching elements both set to actuate or de-actuate at the same set or resetpoint. Each switch one has one normally open, one normally closed, and one common terminal. The switches are independent of each other and can be wired to two independent circuits. The two circuits can either normally open (N/O) or normally closed (N/C).

Snap Action – In switch terminology, snap action generally refers to the action of contacts in the switch element. These contacts open and close quickly and snap closed with sufficient pressure to firmly establish an electrical circuit. The term distinguishes products from mercury bottle types that were subject to vibration problems.